

# Yukon Green and Sustainable Purchasing Workshop

Presented by:

Yukon Intergovernmental Committee  
on Environmental Sustainability (YICES)

October 25<sup>th</sup> , 2011

# Welcome & Kick-off

## Speakers:

- **Shannon Albisser**  
Yukon Federal Council Secretariat- welcome from YICES
- **Mary Decker**  
First Nations <insert title>
- **Mike Johnson**  
Deputy Minister, Highways and Public Works, Yukon Govern.
- **Tim Reeve**  
President, Reeve Consulting

# Workshop Vision

The workshop will help staff from all orders of government and other interested organizations to **build the skills and organizational capacity for implementing green and sustainable purchasing programs and will catalyze networking** between municipal, territorial, First Nations, and federal governments on green purchasing and related sustainability initiatives.

# Learning Objectives for the Day

- Define green and sustainable purchasing
- Examine drivers and leading practices
- Outline resource needs for robust programs
- Demonstrate the value of sustainable purchasing
- Inspire participants to adopt green purchasing practices
- Facilitate networking between governments and organizations

# Audience Profile

- Directors and senior managers
- Purchasing and procurement staff
- Sustainability leaders / Green team members
- Administrative staff
- Local politicians and other stakeholders

# Workshop Agenda

1. Registration and Refreshments (8:00-8:30 AM)
2. Kick-off and Welcome (8:30-9:00 AM)
3. **Drivers for Public Sector Sustainable Purchasing (9:00 -10:15 AM)**
4. Coffee Break (10:15–10:30 AM)
5. Sustainable Purchasing Trends & Best Practices (10:30 -11:45 AM)
6. Lunch Break (11:45 AM – 12:30 PM) and Keynote Lunch Speaker (12:30-1:15 PM)
7. Afternoon Plenary Session – Diving Deep on Sustainable Purchasing (1:15-2:45 PM)
8. Coffee Break (2:45 – 3:00 PM)
9. Concurrent Breakout Sessions – Choose One (3:00-4:00 PM)
10. Wrap-up, Next Steps & Evaluation (4:00-4:30 PM)

# Drivers for Public Sector Sustainable Purchasing

## Speakers:

- **David Knight**

Manager, Procurement Services, Highways and Public Works, Yukon Government

- **Melissa Hall**

Procurement Advisor, Corporate Services, Aboriginal Affairs & Northern Development Canada (AANDC)

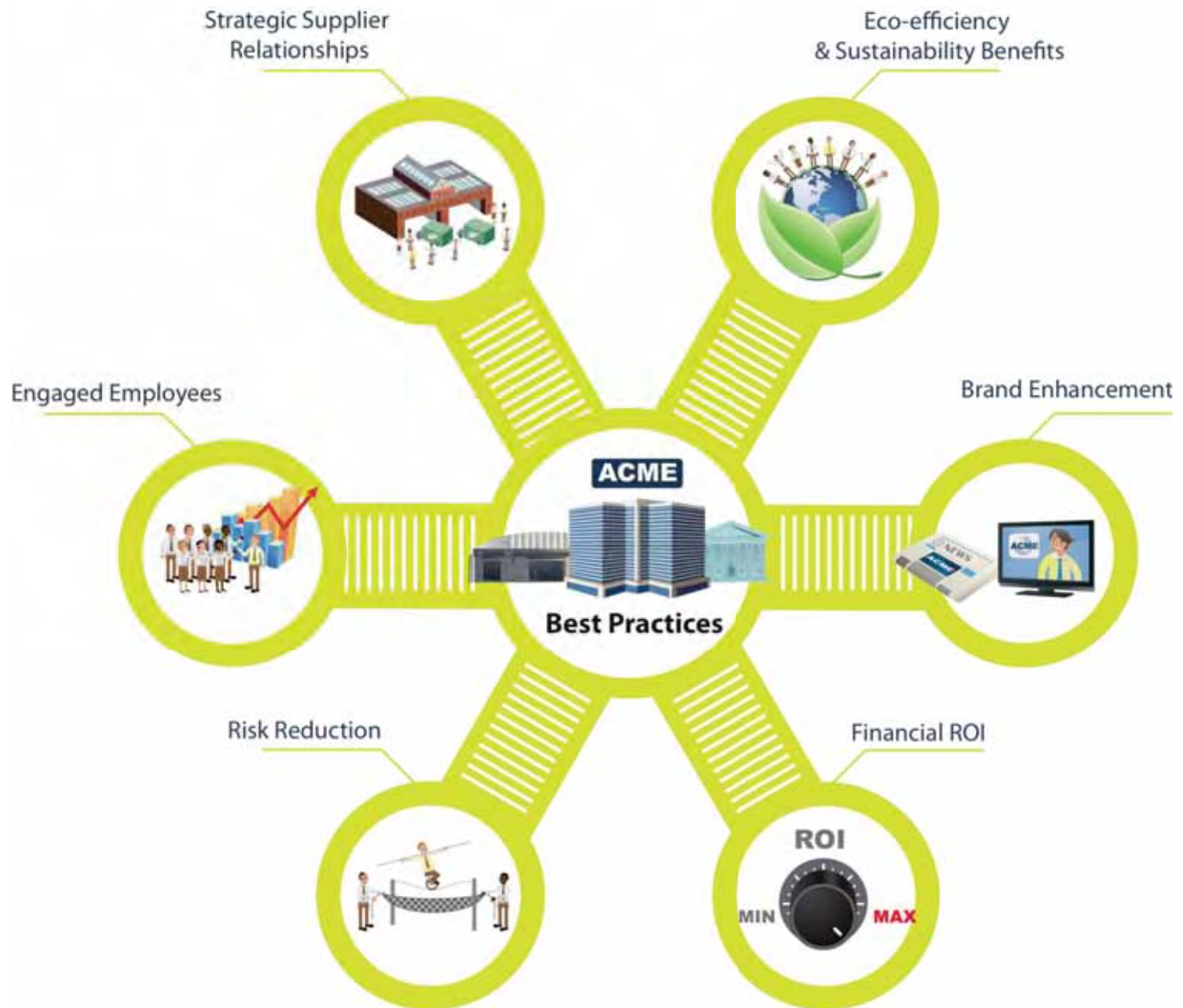

# What is Sustainable Purchasing?

*The term **sustainable purchasing** means placing purchasing priority on price, quality and service, but also on the environmental and socio-economic impacts of a product or service and the sustainability leadership performance of suppliers.*

# What is Sustainable Purchasing?

*Sustainable purchasing is buying products and services that:*

- *Demonstrate great price, quality and service*
- *Offer a 'green' or 'sustainability premium'*
- *From suppliers who are demonstrating 'green' leadership*

# Green Purchasing



# Eco Procurement



# Environmentally Preferable



# Buying Local



# Eco-certifications



# Eco-certifications



# Ethical Purchasing



# Fair Trade Purchasing

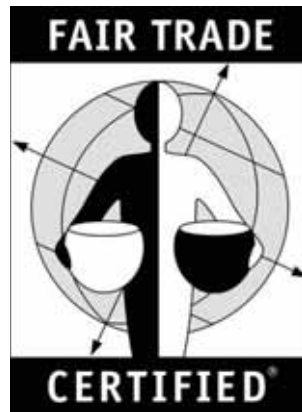

# Sustainable Supply Chains



# Green & Sustainable Purchasing in Action

1. Product /  
Service  
Sustainability  
Specifications



2.  
Sustainability  
Leadership  
Questionnaire



3. Supplier  
Code of  
Conduct



# What is Sustainable Purchasing?

*Research shows that environmental preferable or “green” purchasing is top priority for most public organizations in Canada.*

# Your Challenge

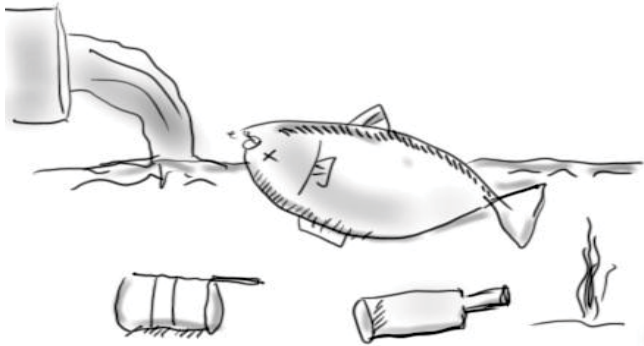

Water Pollution

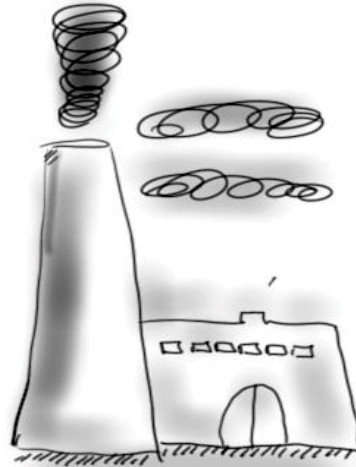

Carbon Emissions



Waste & Packaging



Disengaged Employees



Supplier Frustrations

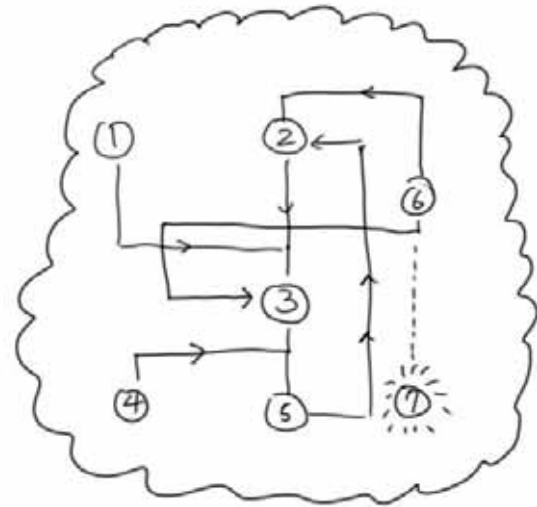

Inefficient processes

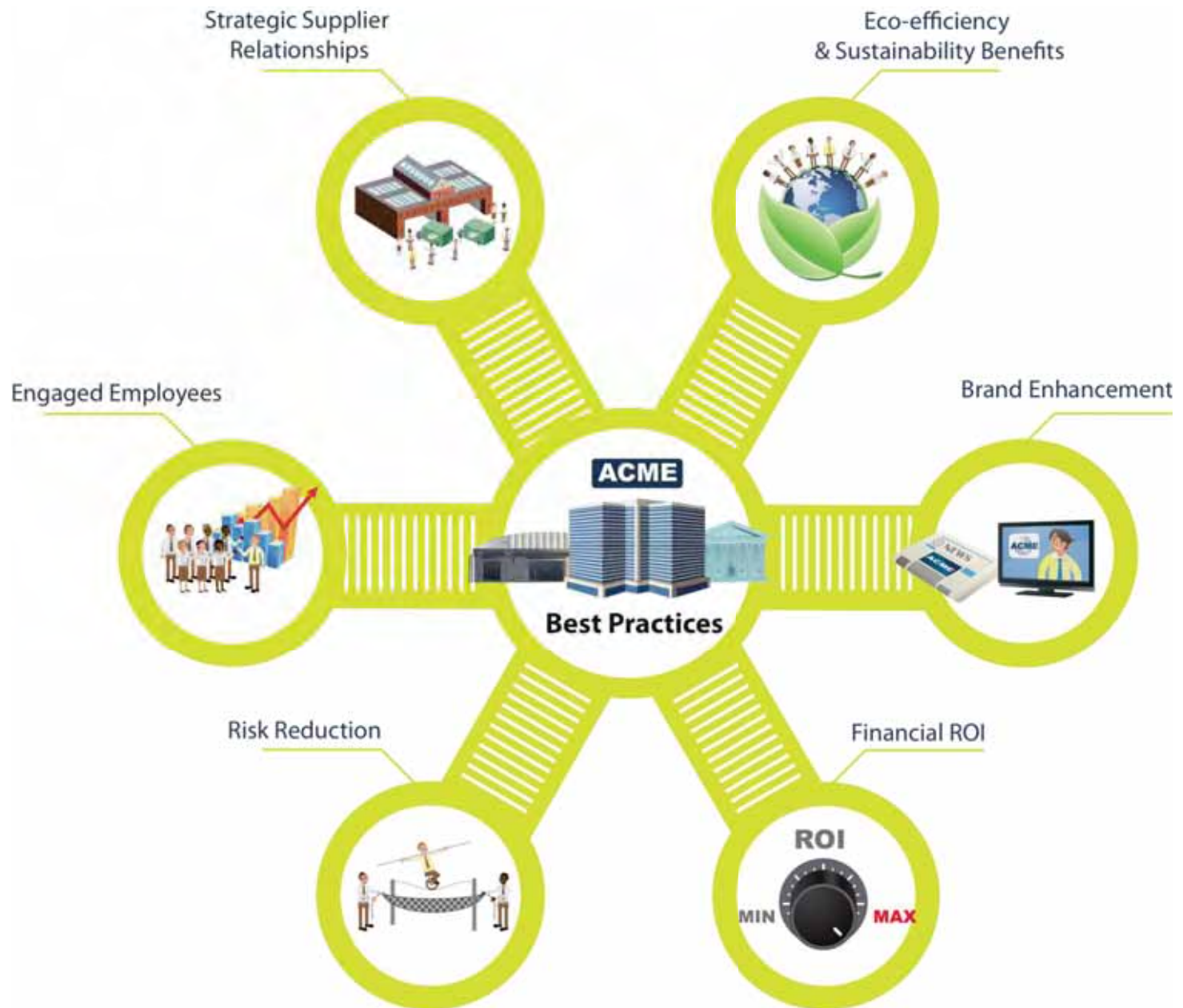

# Drivers for Public Sector Sustainable Purchasing

- **David Knight**

Manager, Procurement Services, Highways and Public Works,  
Yukon Government

-place holder for David's slides

# Drivers for Public Sector Sustainable Purchasing

- **Melissa Hall**

Procurement Advisor, Corporate Services, Aboriginal Affairs & Northern Development Canada (AANDC)

-place holder for Melissa's slides

# Workshop Agenda

1. Registration and Refreshments (8:00-8:30 AM)
2. Kick-off and Welcome (8:30-9:00 AM)
3. Drivers for Public Sector Sustainable Purchasing (9:00 -10:15 AM)
4. **Coffee Break (10:15–10:30 AM)**
5. Sustainable Purchasing Trends & Best Practices (10:30 -11:45 AM)
6. Lunch Break (11:45 AM – 12:30 PM) and Keynote Lunch Speaker (12:30-1:15 PM)
7. Afternoon Plenary Session – Diving Deep on Sustainable Purchasing (1:15-2:45 PM)
8. Coffee Break (2:45 – 3:00 PM)
9. Concurrent Breakout Sessions – Choose One (3:00-4:00 PM)
10. Wrap-up, Next Steps & Evaluation (4:00-4:30 PM)



# Sustainable Purchasing Trends & Best Practices

- **Tim Reeve**  
President, Reeve Consulting

# Exploding Trend



## International Movement



# Trends & Best Practices in Canadian Municipal Sustainable Purchasing

## Summary Report

A report by Reeve Consulting commissioned by the  
Canadian Municipal Collaboration for  
Sustainable Purchasing

December 2010



# Edmonton

THE CITY OF

# Some Examples...

## SEEPP



The screenshot shows a web browser window displaying the City of Calgary's website. The page title is "Sustainable Environmental & Ethical Procurement Policy (SEEPP)". The main content area features a "February 2008 Update" section with the heading "Report on Successful SEEPP Pilot to be Submitted to Standing Policy Committee". Below this, there is a paragraph of text and a bulleted list of updates. A sidebar on the left contains a navigation menu for the SEEPP page, and a sidebar on the right contains "Related Links" and "Downloads" sections.

**Sustainable Environmental & Ethical Procurement Policy (SEEPP)**

**February 2008 Update**

**Report on Successful SEEPP Pilot to be Submitted to Standing Policy Committee**

The SEEPP pilot was successful and is nearing completion. A draft report outlining the results of the pilot is currently being circulated to senior City managers. The final report, which will be available to the public on March 7, will be presented to the Standing Policy Committee (SPC) on Finance & Corporate Services on March 12.

An additional stakeholder information session was held on Jan. 20, 2008, in the large banquet hall of the Municipal Building. Results from the research related to the pilot were presented and stakeholders were made aware of the best practices going forward. These include:

- Draft report submitted to Departmental General Manager Feb. 20
- Final report submitted to City Clerk's Office Feb. 28
- Final report posted to the City website March 7
- Presentation to SPC on Finance & Corporate Services March 12

The SPC meeting will begin at 9:30 a.m. and will be located in the engineering/traditions committee room, first floor, old city hall. The meeting will be open to the public. The final report will be available in the SPC meeting agenda & minutes of Council/committees.

Please refer to [stakeholder sessions](#) for more information.

**Related Links**

- [Investment Library](#)
- [Triple Bottom Line Policy Framework](#)
- [The Business Principles](#)
- [Governmental Policy](#)
- [Strategic Governmental Initiatives](#)

**Downloads**

- [Final Document Approval & Product 11 \(11-1-08\)](#)
- [Final Document Approval & Service 11 \(11-1-08\)](#)



Policy



Procedures



Procurement Toolkit



Shopping List



KPI's & Targets

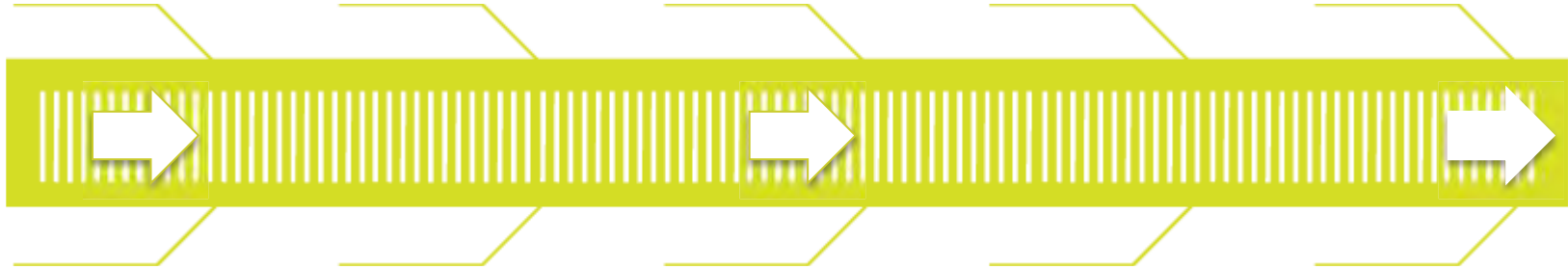

Code of Conduct

Audit Program

Implementation Plan

Outreach

Training



# Strategic Action Planning



- Define program priorities
- Select key products & initiatives
- Set KPIs & targets
- Outline reporting system
- Pareto Principle

# Corporate Commitment & Guidelines



- Sustainable Purchasing Policy
- Supplier Code of Conduct
- Triple-bottom-line guidelines



# CITY POLICY

POLICY NUMBER: C556

**REFERENCE:**

The Way Ahead: City Strategic Plan, 2009-2018  
The Way We Green: Environmental Strategic Plan, 2006  
Environmental Policy C512  
Environmental Management System Policy C505  
Conservation of Natural Sites Policy C467  
Sustainable Building Policy C532  
Diversity and Inclusion Policy C538  
Respectful Workplace A1147  
Purchasing of Goods, Services and Construction A1439  
Purchasing Light Duty Vehicles A1451  
Corporate Procurement Card Procedures

**ADOPTED BY:**

City Council  
3 February 2010

**SUPERSEDES:**

New

**PREPARED BY:** Corporate Services Department

**DATE:** 31 December 2009

**TITLE:** Sustainable Purchasing

Page 1 of 2

**Policy Statement:**

The City of Edmonton recognizes that through its engagement with the public market it has the power to bring about environmental and social improvements both locally and globally while maximizing economic benefits. The Sustainable Purchasing Policy is a framework for purchasing decision-making that will contribute to the City's strategic goals of *Preserving and Sustaining Edmonton's Environment* and *Diversifying and Strengthening Edmonton's Economy*.



## Wood Purchasing

- [Production & Consumption](#)
- [Our Wood Sources](#)
- [Forest Lands Coverage](#)
- [Product Shifts](#)
- [Certification](#)
- [FAQs](#)
- [Glossary](#)

▸ [THD And The Environment](#)



### Other Sites To Visit

[Forest Ethics](#)  
[Rainforest Alliance](#)  
[The Nature Conservancy](#)  
[Natural Resources Defense Council](#)  
[USDA Forest Service](#)  
[World Wildlife Fund](#)  
[Canadian Forest Service](#)  
[Food and Agriculture Organization of The](#)

### Wood Purchasing Policy

As the world's largest home improvement retailer and an industry leader on sustainability issues, we have the ability to effect change by doing the right thing. To help protect endangered forests and to ensure that there will be timber for future generations, The Home Depot first issued its Wood Purchasing Policy in 1999. From 1999 through 2008 we have been very successful in leading our suppliers to understanding and practicing sustainable forestry throughout the world.

We pledged to give preference to wood that has come from forests managed in a responsible way and to eliminate wood purchases from endangered regions of the world.

## Our Supplier Code of Conduct



### Trustworthy Suppliers

As we consider new ways to think and act internally, we're also enhancing our interaction with supplier, government and community stakeholders to improve our social and environmental performance.



## featured news

NOVEMBER 4, 2008

### **Walmart Sustainability Team Visits NCE Labs**

Representatives from Walmart's Sustainability Team including Matt Kistler, Senior Vice President for Sustainability visited with researchers and students of the National Center of Excellence on SMART Innovations in addition to touring various NCE laboratories. The visit allowed NCE researchers to present on their energy and climate strategy and technology innovations aimed at increasing the sustainability of consumer products. This is the 3rd such visit by Walmart executives including a 2007 visit by Rob Walton, Chairman of the Board of Walmart.

# Tools & Procedures



- Contract Clauses & Specifications
- Supplier Evaluation Tools
- Weighting Schemes
- Disclosure Forms
- FAQ's

**City of Vancouver**  
**Assessment of Vendor Leadership Questionnaire**

As part of the City's Ethical Purchasing Policy (EPP) and the Sustainable and Ethical Procurement Policy (SEPP), all City vendors must meet minimum requirements related to ethical, social and environmental standards. Beyond these basic requirements, the City would also like to acknowledge vendors that are demonstrating leadership and innovation in sustainability. In order to be able to do so, The City requires that all suppliers bidding on a City contract complete this questionnaire.

Check as many answers as applicable for your organization. You will need to verify all your answers to The City upon request. Please keep in mind that these questions are relevant to both your company's internal operations as well as the facilities or sub-contractors you work with to supply The City.

***Section 1: Fair Workplace Practices***

- |   |                              |                             |
|---|------------------------------|-----------------------------|
| <b>1. Does your company know the locations of 100% of the facilities that produce your products</b>   | <input type="checkbox"/> Yes | <input type="checkbox"/> No |
| <b>2. Does your company have a documented Supplier Code of Conduct or policy that sets internationally recognized minimum labour standards that you expect your suppliers to meet when manufacturing your products?</b> | <input type="checkbox"/> Yes | <input type="checkbox"/> No |
| <b>3. Does your company verify supplier compliance to the standards in the Supplier Code of Conduct or policy?</b>  |                              |                             |
| a) We conduct third party audits of factories we work with  | <input type="checkbox"/> Yes | <input type="checkbox"/> No |
| b) We conduct internal audits of our supply chain and work with our supply base to resolve issues   | <input type="checkbox"/> Yes | <input type="checkbox"/> No |
| c) We publicly disclose the names and locations of our factories  | <input type="checkbox"/> Yes | <input type="checkbox"/> No |
| d) We rely on a complaint-based system  | <input type="checkbox"/> Yes | <input type="checkbox"/> No |
| <b>4. Is your company a member of any organization that works to promote fair and reasonable employment conditions for workers within your facilities or factories?</b>   |                              |                             |

# Communication & Training



- Key Audiences & Messages
- Program Design Consultations
- Training your staff



## Engaging with Suppliers

- Outreach strategy
- Strategic partnerships
- Recognition of leadership
- Identifying barriers and opportunities



**100%**

Exclusive Brands overseas factories audited — a total of 196 — through our factory auditing program

PROGRAMS + INITIATIVES

# Supply chain

We invest significant time and resources to not only audit factories that make our products, but to work with them to improve environmental, workplace and labor standards.

# Measuring, Reporting and Transparency



- Verification and auditing
- Tracking system development
- Annual reporting
- Continuous improvement
- Redefining targets

# Resourcing the Program



- Create a team
- Allocate adequate funding
- Ensure accountability

# Leadership & Collaboration



- Consortiums & networks
- Sharing knowledge
- Collaborative audit processes

# Canadian Municipal Collaboration for Sustainable Purchasing







# Official List of High Priority Procurements



Environmental and Sustainable Procurement Project  
Deliverable # 4.2



## Official List of High-Priority Environmental and Sustainable Procurements

### Selection Criteria for High-Impact Environmental and Sustainable Procurement Opportunities :

High Volume / High Value	Purchased in significant quantities across the organization, or in high volume by one area
Environmental risk/opportunity	Posses a significant environmental risk or can contribute significantly to a reduced environmental footprint
Significant public profile	High real or symbolic value with the public or other stakeholders
Mature market	Proven quality and availability within the marketplace for an environmental product
Third-party certification	Recognized independent certification exists for the product
Social risk/ opportunity	Posses a significant social risk (i.e. hazardous waste in third world countries) or can contribute significantly to improved social conditions in the supply chain (i.e. encouraging development in disadvantaged groups)

Table 1: Priority Sustainable Products and Services

Product / Service Description	Selection Criteria	Vendor/Contract Expiry Data	Additional Information & Recommended Specifications
<p><b>Overlay products and materials:</b></p> <ul style="list-style-type: none"> <li>• Tents and Tent Construction</li> <li>• Flag poles</li> <li>• Seats</li> <li>• Podiums</li> <li>• Judges/spectator services chairs</li> <li>• Parking and routing dividers</li> <li>• Overlay platforms and wrap</li> </ul> <p><u>Function:</u> Construction/ Overlay</p>	<ul style="list-style-type: none"> <li><input type="checkbox"/> High volume</li> <li><input type="checkbox"/> Environmental risk /opportunity</li> <li><input type="checkbox"/> Mature market</li> <li><input type="checkbox"/> Third-party certification</li> <li><input type="checkbox"/> Significant public profile</li> <li><input type="checkbox"/> Social risk / opportunity</li> </ul>		<p><u>Risks:</u></p> <ul style="list-style-type: none"> <li>• Excessive waste</li> </ul> <p><u>Opportunities:</u></p> <ul style="list-style-type: none"> <li>• Local sub-contract opportunity (local fabrication shop)</li> <li>• Social inclusion through training opportunities and development</li> <li>• Renting or leasing opportunity</li> </ul> <p><u>Recommended Specifications:</u></p> <ul style="list-style-type: none"> <li>• FSC certified wood or equivalent</li> <li>• Recyclable overlay wrap</li> <li>• High-use potential for tents and other purchased equipment</li> </ul>

# King County Savings

2010 cost savings results from sustainable purchasing program

Commodity	2010 Savings
Aggregates	300,000
Toner Cartridges	222,830
Tire Retreading	264,578
Green Cleaners	132,735
Antifreeze	17,175
Motor Oil	61,004
<b>Total Dollars:</b>	<b>\$998,322</b>

# King County's Paper Goals

- 2012 Goal: reduce copy paper consumption by 20% and increase purchase of 100% recycled content

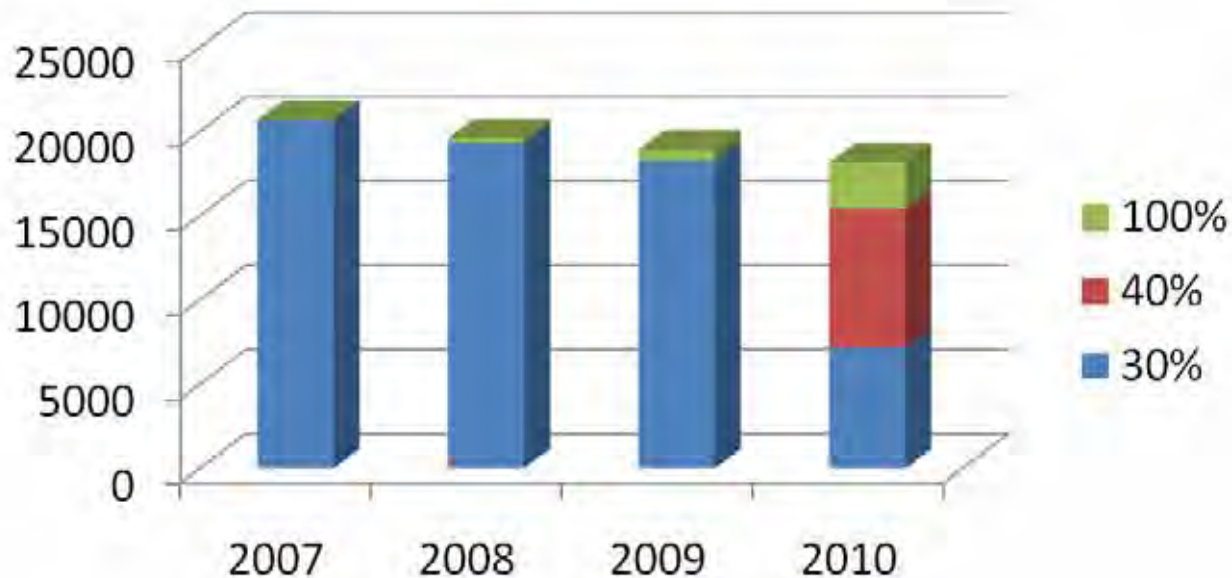

# Green Cleaners



Cleaning Protocols



Chemical Use Reduction



Worker Health & Safety



Certified Cleaners



Microfiber Cloths & Mops



Cost Savings



# Computers

- EPEAT products
  - Desktops
  - Laptops
  - Monitors
  - 90% EPEAT Gold
- GHG reductions
- Electronics recycling contract
  - BAN's e-Steward Recycler
- Energy saving software
  - 38% savings in one year



# Re-refined Motor Oil

- Meets API specs
- Used in county cars and trucks
- 1300 buses
- Closed loop recycling
- Saved \$21,000 in 2010
- \$40,000 in revenue





# 5 Most Commonly Sourced Green Products



1. Recycled copy paper & office supplies
2. Non-toxic cleaning supplies
3. Energy saving IT equipment, electronics and infrastructure (e.g. lighting)
4. Non-toxic building products (e.g. paint) & furniture
5. Green vehicle fleets

# 2010 Olympic Games



## Buy Smart Program

Microsoft Internet Explorer  
http://www.vancouver2010.com/en/sustainability/sustainableprocurement/buySmartProgram

13 days of Olympic Games Events - February 12 to 28, 2010  
10 days of Paralympic Games Events - March 12 to 21, 2010

**THE BUYER'S GUIDE** | **PARTICIPATION** | **FACTORS AND EVALUATION** | **SUPPORT SERVICES** | **SUSTAINABLE SUPPLIERS** | **LINKS**

**Sustainability**  
Accountability  
Environmental Stewardship and Impact Reduction  
Social Transparency and Corporate Citizenship  
Accountability/Integrity  
Economic Benefits  
Efficient Performance  
Responsible  
Partnership, Learning and Business Development

**Buy Smart Program**  
Buy Smart, Sustainable Procurement Framework  
Supplier Code of Conduct  
Supplier and Overall Sustainability in Action (VANCOC, Suppliers and the Industry Factor)  
Challenges of Being Sustainable Suppliers  
Sustainable Decision

**Buy Smart Program**  
Our Buy Smart Program is a formalized set of processes and best practices and activities. It is designed to ensure sustainability, ethical choices and Aboriginal participation in Vancouver 2010 account settings and procurement and sourcing activities. These processes are informed by stakeholder input and best practices.

When bidding on VANCOC procure opportunities, prospective suppliers are asked to include information on their environmental programs and the degree to which they are:

- Aboriginal owned (or employ Aboriginal people)
- Based in one of Vancouver's three green job communities (or employ from the community)
- Provide opportunities for people with a disability or other sustainability focused.

Along with price, quality and technical performance considerations, this information is factored into VANCOC's decision making. Licenses of merchandise bearing the Olympic rings must also comply with VANCOC's official License Code of Conduct that sets out requirements for safe, healthy and environmentally responsible workplaces and facilities. We also collaborate with The 2010 Concurrence Centre to identify firms with a track record and all related features will ensure that they have about our bidding opportunities and are in a position to respond to buyer-related requests for proposals directly or by sub-contracting or joint venturing with other firms.

**Buy Smart Steering Committee**

**SUBSCRIBE**  
Subscribe to receive updates from the Buy Smart Program  
 General Updates  
 Alerts to Opportunities  
 News and Updates  
 The Trade Portal  
E-mail:

**COUNTERPARTY TO THE GAMES**  
Be part of the excitement  
**THE OLYMPIC STORE**

**MEET THE PROJECTS**

# Richmond Olympic Oval

- BC Pine Beetle Wood Roof
- Venues' Aboriginal Art Program
- Rainwater Capture and Reuse



# RONA Fab Shop



# Ethical Merchandising



SUSTAINABILITY IN ACTION

# Community Benefit Agreements



# Supplier Code of Conduct



SUSTAINABILITY IN ACTION

PUTTING OUT FIRES



---

Code



Code



**Assessment of Leadership Vendor Questionnaire**

of Calgary has a Supplier Code of Conduct (SCC) that serves as a minimum standard for ethical performance. The City would like to acknowledge companies that go beyond the basic tenets regarding ethical, social and environmental performance. In order to be able to do so, all are required to fill out this questionnaire.

many answers as applicable for your organization and fill in name of organization, your name and then sign the document. You will need to verify all your answers to The City of Calgary upon Please keep in mind that these questions are relevant to both your company's internal as well as the facilities or sub-contractors you work with to supply The City.

**Supply Chain Management**

**1. Does your organization have a documented Supplier Code of Conduct (SCC) that sets internationally recognized minimum labour standards that you expect your suppliers to meet when manufacturing your products?**

- a) Yes
- b) No

**2. How does your company verify supplier compliance to the standards in the SCC? – total 17 pts**

- a) We conduct third party audits of the factories we work with
- b) We publicly disclose the names and locations of our factories
- c) We rely on a complaint-based system
- d) We do not verify compliance

**3. Is your organization a member of any organization that works to promote workers fair and reasonable employment conditions within your facilities or factories? (Check off as many answers as relevant)**

- a) Yes, we are members of Fair Labour Association or Social Accountability International or Worker's Rights Consortium
- b) Yes, we are member of Fair Factories Clearinghouse or Sedex (S)
- c) Yes, other \_\_\_\_\_
- d) We are not members of any such organization

**Workplace Health and Safety & Wage Rates**

**4. Tell us how your company works to promote workplace health and safety. (Check off as many answers as relevant)**

- a) We have a documented Health & Safety Policy
- b) We have a Health & Safety Manual that includes safe work procedures
- c) We conduct hazard assessments and job task-specific health & safety training
- d) We conduct external safety audits
- e) We conduct safety inspections
- f) We are registered with one or more of these Safety Management System/Program: BSI 18001 or CAN/CSA 21000 or ANSI Z10
- g) We do not have a program to promote workplace health and safety

**5. Does your organization pay its staff in Alberta a living wage? (Choose one of the following options)**

- a) Yes, we pay our staff a minimum of \$13.25 per hour
- b) Yes, we pay our staff a minimum of \$12.00 per hour plus benefits
- c) We do not pay our staff a living wage

Code



**Assessment of Leadership Vendor Questionnaire**

of Calgary has a Supplier Code of Conduct (SCC) that serves as a minimum standard for ethical performance. The City would like to acknowledge companies that go beyond the basic tenets regarding ethical, social and environmental performance. In order to be able to do so, all are required to fill out this questionnaire.

many answers as applicable for your organization and fill in name of organization, your name and then sign the document. You will need to verify all your answers to The City of Calgary upon Please keep in mind that these questions are relevant to both your company's internal as well as the facilities or sub-contractors you work with to supply The City.

**Supply Chain Management**

**1. Does your organization have a documented Supplier Code of Conduct (SCC) that sets internationally recognized minimum labour standards that you expect your suppliers to meet when manufacturing your products?**

- a) Yes
- b) No

**2. How does your company verify supplier compliance to the standards in the SCC? – total 17 pts**

- a) We conduct third party audits of the factories we work with
- b) We publicly disclose the names and locations of our factories
- c) We rely on a complaint-based system
- d) We do not verify compliance

**3. Is your organization a member of any organization that works to promote workers fair and reasonable employment conditions within your facilities or factories? (Check off as many answers as relevant)**

- a) Yes, we are members of Fair Labour Association or Social Accountability International or Worker's Rights Consortium
- b) Yes, we are member of Fair Factories Clearinghouse or Sedex (S)
- c) Yes, other \_\_\_\_\_
- d) We are not members of any such organization

**Workplace Health and Safety & Wage Rates**

**4. Tell us how your company works to promote workplace health and safety. (Check off as many answers as relevant)**

- a) We have a documented Health & Safety Policy
- b) We have a Health & Safety Manual that includes safe work procedures
- c) We conduct hazard assessments and job task-specific health & safety training
- d) We conduct external safety audits
- e) We conduct safety inspections
- f) We are registered with one or more of these Safety Management System/Program: BSI 18001 or CAN/CSA Z1000 or ANSI Z10
- g) We do not have a program to promote workplace health and safety

**5. Does your organization pay its staff in Alberta a living wage? (Choose one of the following options)**

- a) Yes, we pay our staff a minimum of \$13.25 per hour
- b) Yes, we pay our staff a minimum of \$12.00 per hour plus benefits
- c) We do not pay our staff a living wage

Code



**Assessment of Leadership Vendor Questionnaire**

of Calgary has a Supplier Code of Conduct (SCC) that serves as a minimum standard for ethical performance. The City would like to acknowledge companies that go beyond the basic tenets regarding ethical, social and environmental performance. In order to be able to do so, all are required to fill out this questionnaire.

Many answers are applicable for your organization and fill in name of organization, your name and then sign the document. You will need to verify all your answers to The City of Calgary upon Please keep in mind that these questions are relevant to both your company's internal as well as the facilities or sub-contractors you work with to supply The City.

**Supply Chain Management**

**1. Does your organization have a documented Supplier Code of Conduct (SCC) that sets internationally recognized minimum labour standards that you expect your suppliers to meet when manufacturing your products?**

- a) Yes
- b) No

**2. How does your company verify supplier compliance to the standards in the SCC? – total 17 pts**

- a) We conduct third party audits of the factories we work with
- b) We publicly disclose the names and locations of our factories
- c) We rely on a complaint-based system
- d) We do not verify compliance

**3. Is your organization a member of any organization that works to promote workers fair and reasonable employment conditions within your facilities or factories? (Check off as many answers as relevant)**

- a) Yes, we are members of Fair Labour Association or Social Accountability International or Worker's Rights Consortium
- b) Yes, we are member of Fair Factories Clearinghouse or Sedex (S)
- c) Yes, other \_\_\_\_\_
- d) We are not members of any such organization

**Workplace Health and Safety & Wage Rates**

**4. Tell us how your company works to promote workplace health and safety. (Check off as many answers as relevant)**

- a) We have a documented Health & Safety Policy
- b) We have a Health & Safety Manual that includes safe work procedures
- c) We conduct hazard assessments and job task-specific health & safety training
- d) We conduct external safety audits
- e) We conduct safety inspections
- f) We are registered with one or more of these Safety Management System/Program: BSI 18001 or CAN/CSA Z1000 or ANSI Z10
- g) We do not have a program to promote workplace health and safety

**5. Does your organization pay its staff in Alberta a living wage? (Choose one of the following options)**

- a) Yes, we pay our staff a minimum of \$13.25 per hour
- b) Yes, we pay our staff a minimum of \$12.00 per hour plus benefits
- c) We do not pay our staff a living wage

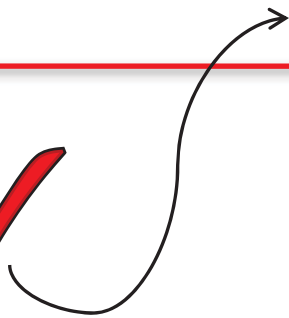

Code

**Assessment of Leadership Vendor Questionnaire**

of Calgary has a Supplier Code of Conduct (SCC) that serves as a minimum standard for ethical performance. The City would like to acknowledge companies that go beyond the basic tenets regarding ethical, social and environmental performance. In order to be able to do so, all are required to fill out this questionnaire.

many answers as applicable for your organization and fill in name of organization, your name and then sign the document. You will need to verify all your answers to The City of Calgary upon Please keep in mind that these questions are relevant to both your company's internal as well as the facilities or sub-contractors you work with to supply The City.

**Supply Chain Management**

**1. Does your organization have a documented Supplier Code of Conduct (SCC) that sets internationally recognized minimum labour standards that you expect your suppliers to meet when manufacturing your products?**

- a) Yes
- b) No

**2. How does your company verify supplier compliance to the standards in the SCC? – total 17 pts**

- a) We conduct third party audits of the factories we work with
- b) We publicly disclose the names and locations of our factories
- c) We rely on a complaint-based system
- d) We do not verify compliance

**3. Is your organization a member of any organization that works to promote workers fair and reasonable employment conditions within your facilities or factories? (Check off as many answers as relevant)**

- a) Yes, we are members of Fair Labour Association or Social Accountability International or Worker's Rights Consortium
- b) Yes, we are member of Fair Factories Clearinghouse or Sedex (S)
- c) Yes, other \_\_\_\_\_
- d) We are not members of any such organization

**Workplace Health and Safety & Wage Rates**

**4. Tell us how your company works to promote workplace health and safety. (Check off as many answers as relevant)**

- a) We have a documented Health & Safety Policy
- b) We have a Health & Safety Manual that includes safe work procedures
- c) We conduct hazard assessments and job task-specific health & safety training
- d) We conduct external safety audits
- e) We conduct safety inspections
- f) We are registered with one or more of these Safety Management System/Program: BSI 18001 or CAN/CSA 21000 or ANSI Z10
- g) We do not have a program to promote workplace health and safety

**5. Does your organization pay its staff in Alberta a living wage? (Choose one of the following options)**

- a) Yes, we pay our staff a minimum of \$13.25 per hour
- b) Yes, we pay our staff a minimum of \$12.00 per hour plus benefits
- c) We do not pay our staff a living wage



Code



**Assessment of Leadership Vendor Questionnaire**

of Calgary has a Supplier Code of Conduct (SCC) that serves as a minimum standard for ethical performance. The City would like to acknowledge companies that go beyond the basic requirements regarding ethical, social and environmental performance. In order to be able to do so, all are required to fill out this questionnaire.

Provide as many answers as applicable for your organization and fill in name of organization, your name and then sign the document. You will need to verify all your answers to The City of Calgary upon request. Please keep in mind that these questions are relevant to both your company's internal operations as well as the facilities or sub-contractors you work with to supply The City.

**Supply Chain Management**

1. Does your organization have a documented Supplier Code of Conduct (SCC) that sets internationally recognized minimum labour standards that you expect your suppliers to meet when manufacturing your products?

- a) Yes
- b) No

2. How does your company verify supplier compliance to the standards in the SCC? -- total 17 pts

- a) We conduct third party audits of the factories we work with
- b) We publicly disclose the names and locations of our factories
- c) We rely on a complaint-based system
- d) We do not verify compliance

3. Is your organization a member of any organization that works to promote workers fair and reasonable employment conditions within your facilities or factories? (Check off as many answers as relevant)

- a) Yes, we are members of Fair Labour Association or Social Accountability International or Worker's Rights Consortium
- b) Yes, we are member of Fair Factories Clearinghouse or Sedex (S)
- c) Yes, other \_\_\_\_\_
- d) We are not members of any such organization

**Workplace Health and Safety & Wage Rates**

4. Tell us how your company works to promote workplace health and safety. (Check off as many answers as relevant)

- a) We have a documented Health & Safety Policy
- b) We have a Health & Safety Manual that includes safe work procedures
- c) We conduct hazard assessments and job task-specific health & safety training
- d) We conduct external safety audits
- e) We conduct safety inspections
- f) We are registered with one or more of these Safety Management System/Program: BSI 18001 or CAN/CSA Z1000 or ANSI Z10
- g) We do not have a program to promote workplace health and safety

5. Does your organization pay its staff in Alberta a living wage? (Choose one of the following options)

- a) Yes, we pay our staff a minimum of \$13.25 per hour
- b) Yes, we pay our staff a minimum of \$12.00 per hour plus benefits
- c) We do not pay our staff a living wage



Code

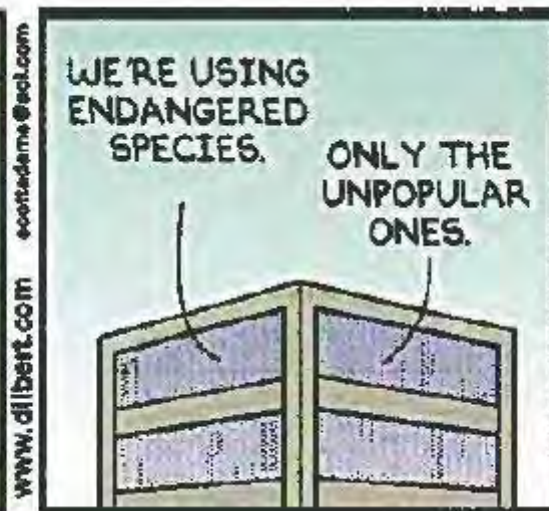

www.dilbert.com

© 2008 Scott Adams, Inc./Dist. by UFS, Inc.

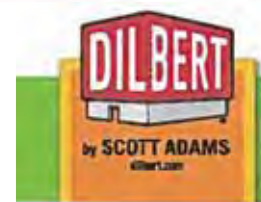

# How it's Done



We use a three-phased approach to get measurable results from

Ethical and Sustainable Purchasing initiatives

# Sustainable Purchasing Timeline

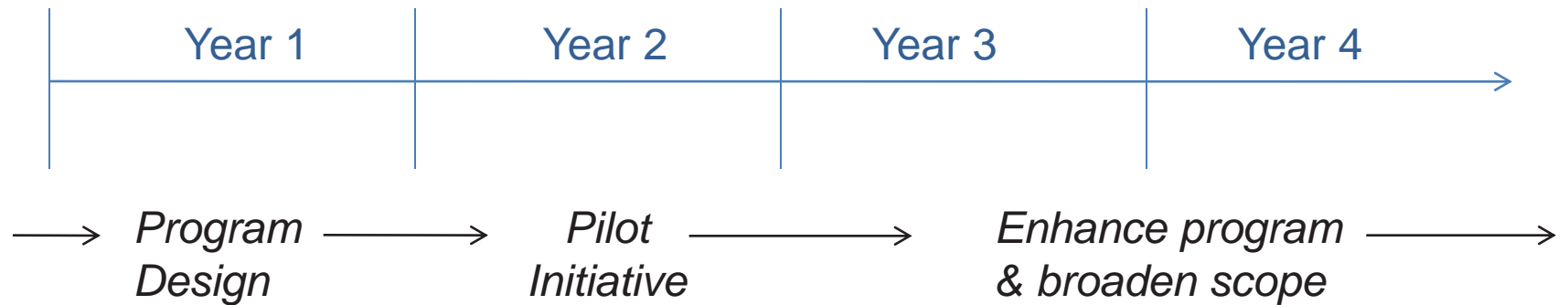

# Workshop Agenda

1. Registration and Refreshments (8:00-8:30 AM)
2. Kick-off and Welcome (8:30-9:00 AM)
3. Drivers for Public Sector Sustainable Purchasing (9:00 -10:15 AM)
4. Coffee Break (10:15–10:30 AM)
5. Sustainable Purchasing Trends & Best Practices (10:30 -11:45 AM)
6. **Lunch Break (11:45 AM – 12:30 PM) & Keynote Lunch Speaker (12:30-1:15 PM)**
7. Afternoon Plenary Session – Diving Deep on Sustainable Purchasing (1:15-2:45 PM)
8. Coffee Break (2:45 – 3:00 PM)
9. Concurrent Breakout Sessions – Choose One (3:00-4:00 PM)
10. Wrap-up, Next Steps & Evaluation (4:00-4:30 PM)

# Lunch Break



11:45 AM – 1:15 PM

# Key Note Speaker

- **Madeleine Plouffe**

Green Procurement Team Leader, Public Works  
Government Services Canada

**-place holder for Madeleine's slides**

# Workshop Agenda

1. Registration and Refreshments (8:00-8:30 AM)
2. Kick-off and Welcome (8:30-9:00 AM)
3. Drivers for Public Sector Sustainable Purchasing (9:00 -10:15 AM)
4. Coffee Break (10:15–10:30 AM)
5. Sustainable Purchasing Trends & Best Practices (10:30 -11:45 AM)
6. Lunch Break (11:45 AM – 12:30 PM) & Keynote Lunch Speaker (12:30-1:15 PM)
7. **Afternoon Plenary Session – Diving Deep on Sustainable Purchasing (1:15-2:45 PM)**
8. Coffee Break (2:45 – 3:00 PM)
9. Concurrent Breakout Sessions – Choose One (3:00-4:00 PM)
10. Wrap-up, Next Steps & Evaluation (4:00-4:30 PM)

# Diving Deep on Sustainable Purchasing

## Speakers:

- **Tim Reeve**  
President, Reeve Consulting
- **Shannon Clohosey**  
Sustainability Projects Manager, City of Whitehorse
- **David Knight**  
Manager, Procurement Services, Highways and Public Works, Yukon Government
- **Melissa Hall**  
Corporate Services, Aboriginal Affairs & Northern Development Canada (AANDC)
- **Lacia Kinnear,**  
Manager of the Northern Climate Exchange, Yukon College

# Diving Deep on Sustainable Purchasing

- Tim Reeve  
President, Reeve Consulting

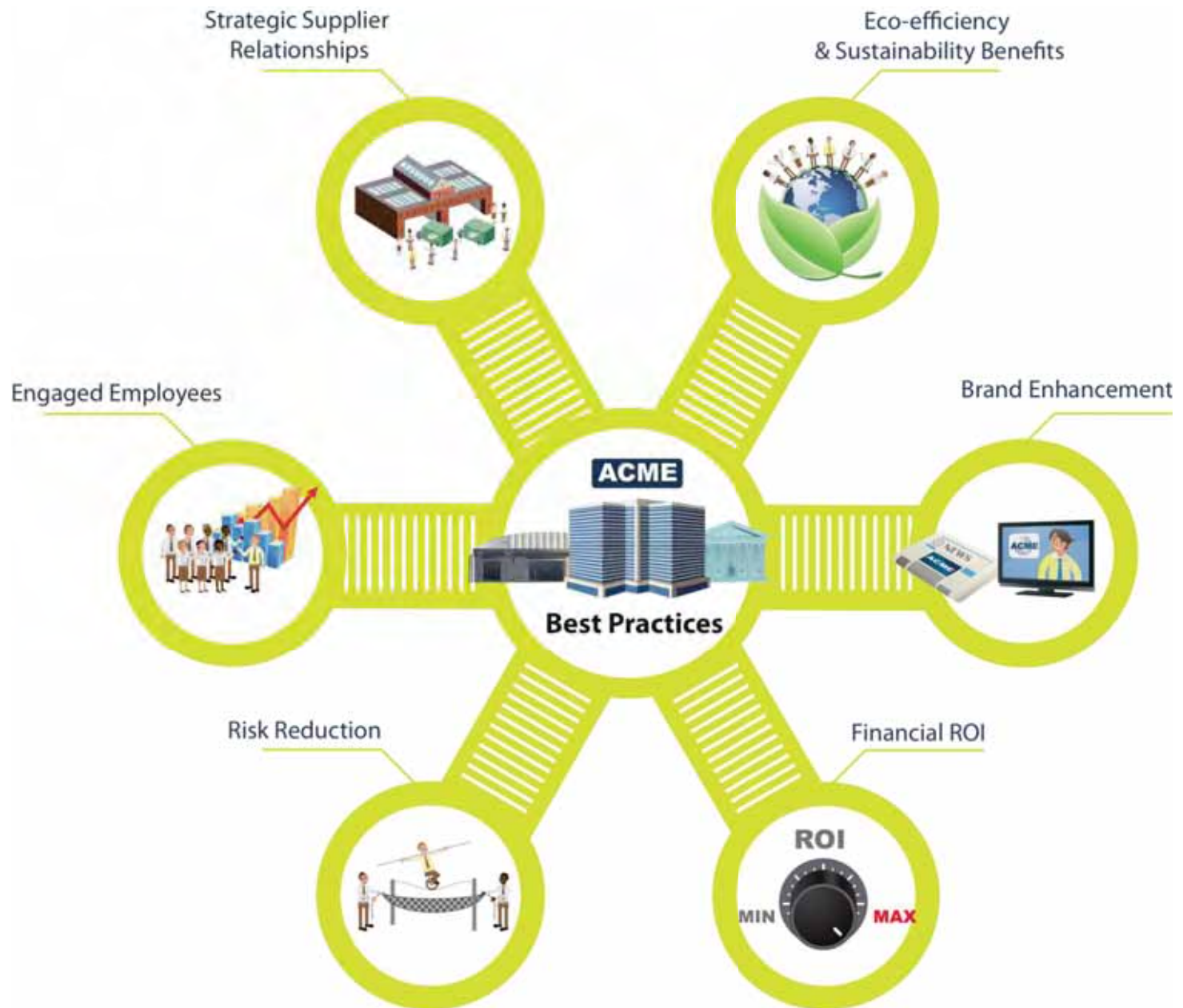



Policy



Procedures



Procurement Toolkit



Shopping List



KPI's & Targets

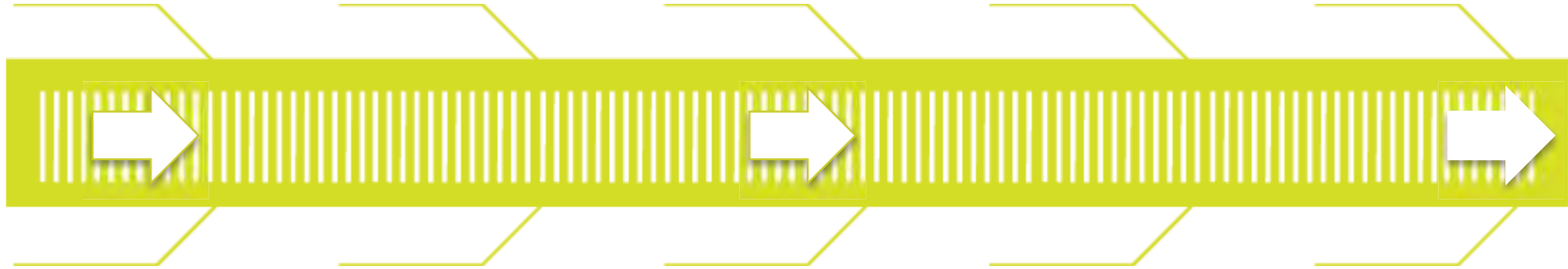

Code of Conduct

Audit Program

Implementation Plan

Outreach

Training

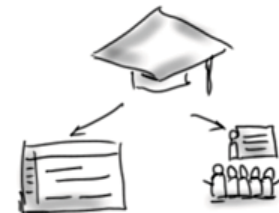

# Sustainable Purchasing Timeline

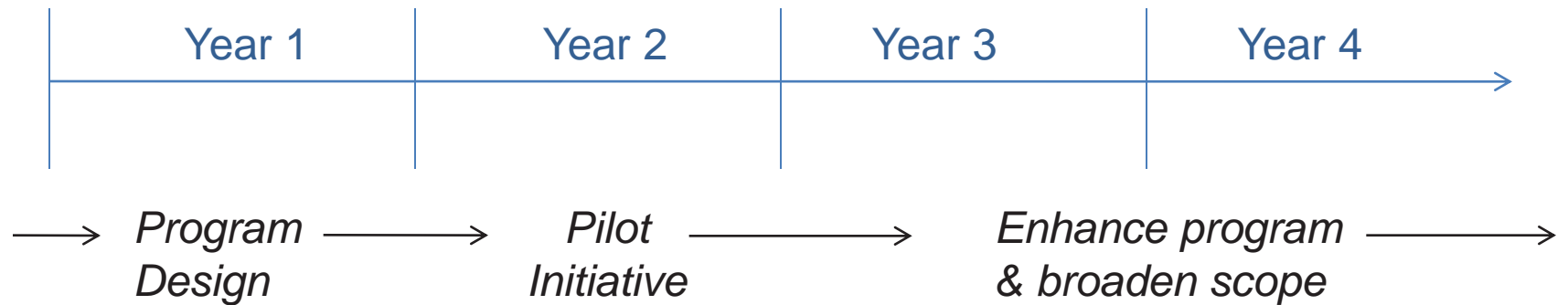

# Injecting Sustainability into Centralized Procurement Processes

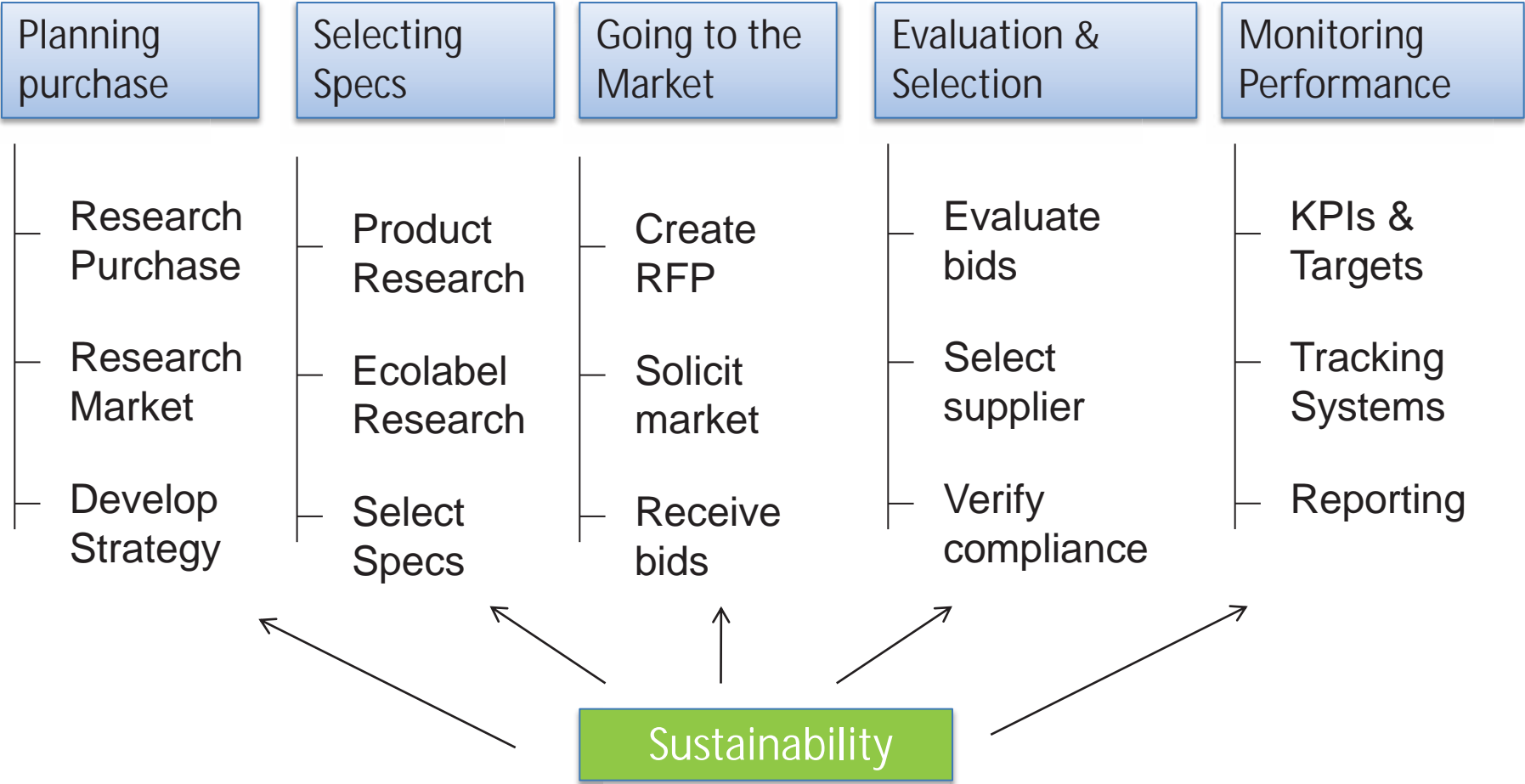

# Injecting Sustainability into Centralized Procurement Processes

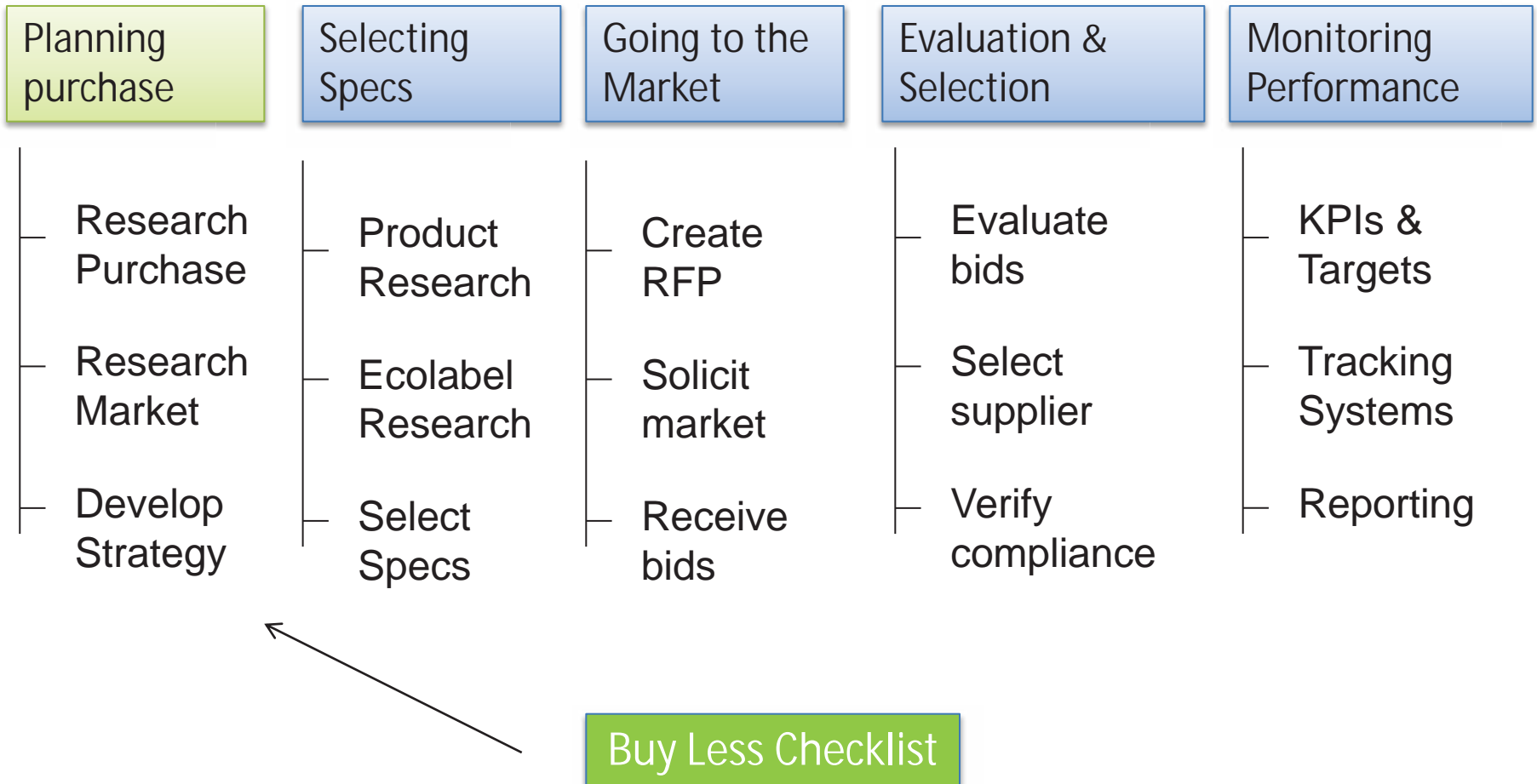

# Injecting Sustainability into Centralized Procurement Processes

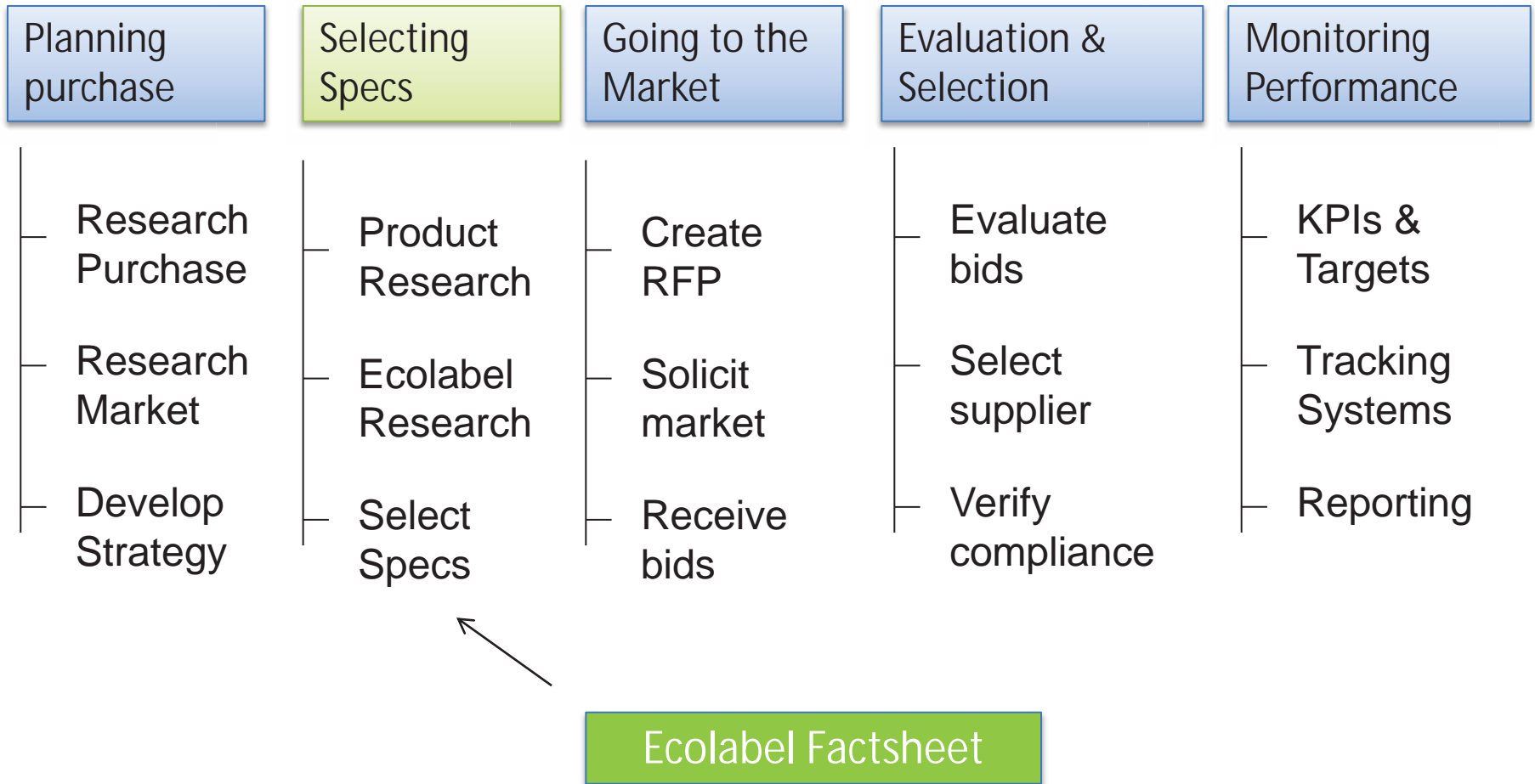

# Injecting Sustainability into Centralized Procurement Processes

City of Vancouver makes EcoLogo standards a mandatory requirement in their Janitorial Services contract



# Injecting Sustainability into Centralized Procurement Processes

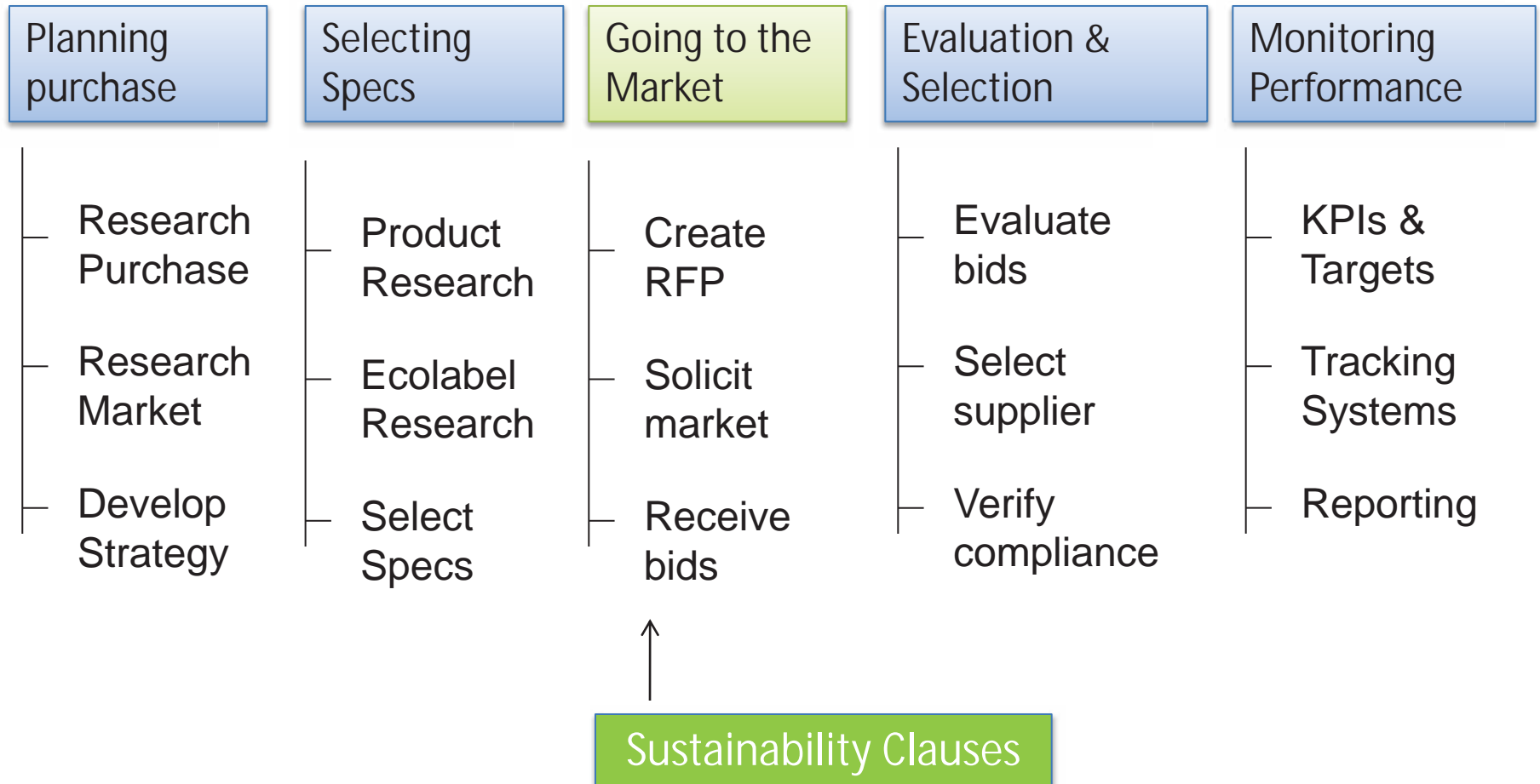

# Injecting Sustainability into Centralized Procurement Processes

City of Edmonton purchasers use a 'Plug-and-Play Sustainability Clauses' tool to select sustainability clauses for their priority sustainable purchasing contracts.



# PLUG & PLAY SUSTAINABILITY CLAUSES

## Packaging Reduction Clause

We aim to reduce the packaging associated with acquiring various products and services. More and more suppliers are introducing innovative programs to reduce packaging. Examples include providing products in reusable packaging such as plastic totes, reducing unnecessary packaging such as shrink wrap or offering packaging that is made from recycled material. Please tell us about any initiatives your company has undertaken to reduce product packaging.

<i>Score</i>	<i>Description</i>
0	No response or information provided not applicable (e.g. not related to product or service in question)
1	The majority of the supplier's packaging is recyclable and can be recycled in the City's recycling system
2	One or more of the following is in place: <ul style="list-style-type: none"><li>• Product packaging is made of high-content post-consumer recycled materials (75% or more) and is fully recyclable</li><li>• Product packaging holds a third-party Type I eco-label (see definitions below), ensuring it meets a set of environmental standards</li><li>• Supplier has a strategy in place to minimize or 'light-weight' packaging</li></ul>
3	Supplier has a product stewardship program in place that addresses one or more of the above attributes and one of the following: <ul style="list-style-type: none"><li>• Supplier packaging is made of high-content post-consumer recycled materials, is fully recyclable and supplier takes back all for recycling</li><li>• Supplier uses reusable containers, made of recycled or eco-friendly materials, and takes back all for reuse</li></ul>

# PLUG & PLAY SUSTAINABILITY CLAUSES

<b>Greenhouse Gas/Carbon Reduction Clause</b>	
<p>We aim to reduce its greenhouse gas/carbon emissions where possible. Tell us how the design and use of your product or service takes into account strategies to reduce greenhouse gas/carbon emissions. Examples could include offering products with a limited amount of embedded carbon, having a strategy for limiting transportation related to service provision and/or purchasing carbon credits to offset emissions.</p>	
<i>Score</i>	<i>Description</i>
0	No response or information provided not applicable (e.g. not related to product or service in question)
1	<p>If one of the following is in place:</p> <ul style="list-style-type: none"> <li>• Product/service delivery uses low emission vehicles</li> <li>• Product production uses alternative energy, such as wind or solar power</li> <li>• Service provider's supplies are produced using wind or solar power</li> <li>• Low emission equipment/machinery used in service provision</li> <li>• Product is designed for energy efficiency</li> </ul>
2	<p>Two or more of the following are in place:</p> <ul style="list-style-type: none"> <li>• Product/service delivery uses low emission vehicles</li> <li>• Product production uses alternative energy, such as wind or solar power</li> <li>• Service provider's supplies are produced using wind or solar power</li> <li>• Low emission equipment/machinery used in service provision</li> <li>• Product is designed for energy efficiency</li> </ul>
3	If two or more of the above attributes are in place and the product/service is verified as carbon neutral by an independent third-party

# Injecting Sustainability into Centralized Procurement Processes

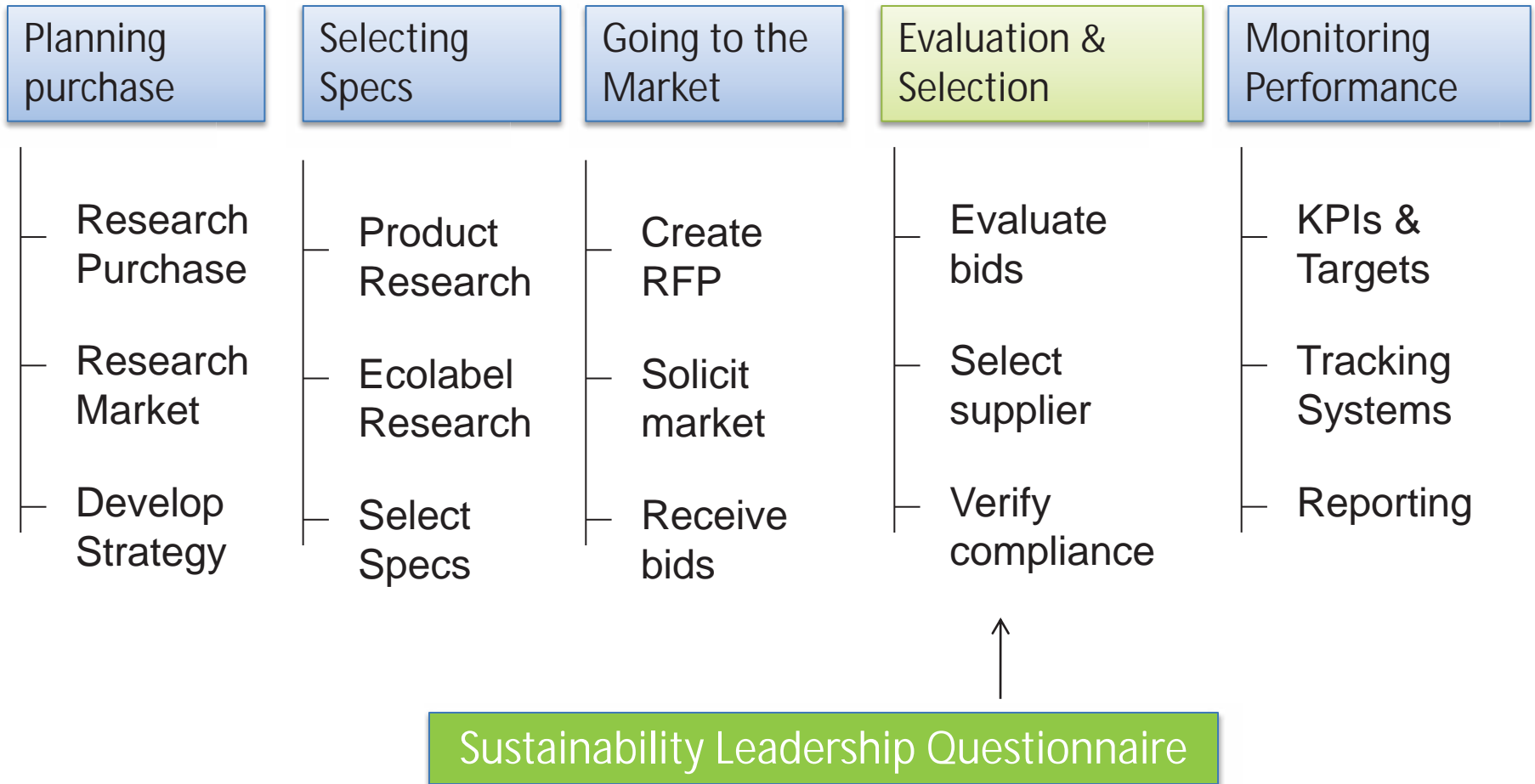

## Supplier Sustainable Leadership Scorecard

j) Have you been compliant with the Workers' Compensation Act or Occupational Health and Safety Regulation over the past five years, e.g. not been issued an order or administrative penalty?  Yes  No

k) When subcontracting work, do you consider and evaluate the health & safety performance of subcontractors prior to awarding contracts?  Yes  No

### 2. Tell us about your strategy to address diversity in your workplace.

a) Do you have a policy or strategy to support hiring a diverse workforce?  Yes  No

b) Do you have a policy or strategy to purchase from diverse contractors/suppliers?  Yes  No

c) Does your company participate in work/employment training programs for vulnerable/diverse populations (e.g. Social purchasing portal)?  Yes  No

### Section 2: Environmental Management & Stewardship

### 3. Tell us what policies and programs your company has in place to manage its environmental impact.

a) Do you have a documented Environmental or Sustainability Policy?  Yes  No

b) Do you have an environmental management system registered to ISO 14001?  Yes  No

c) Do you have a system registered, certified or recognized by another standard (e.g. EMAS)?  Yes  No  
Please specify \_\_\_\_\_

d) Do you have a non-registered audited environmental management system?  Yes  No

e) Do you conduct compliance audits to health, safety and environmental legislation?  Yes  No

f) Do you produce a publicly available annual environmental, CSR, sustainability or accountability report?  Yes  No

# Injecting Sustainability into Centralized Procurement Processes

**WorkCover New South Wales uses a Sustainable Leadership Questionnaire to identify suppliers that are going above and beyond their Supplier Code of Conduct.**



# Injecting Sustainability into Centralized Procurement Processes

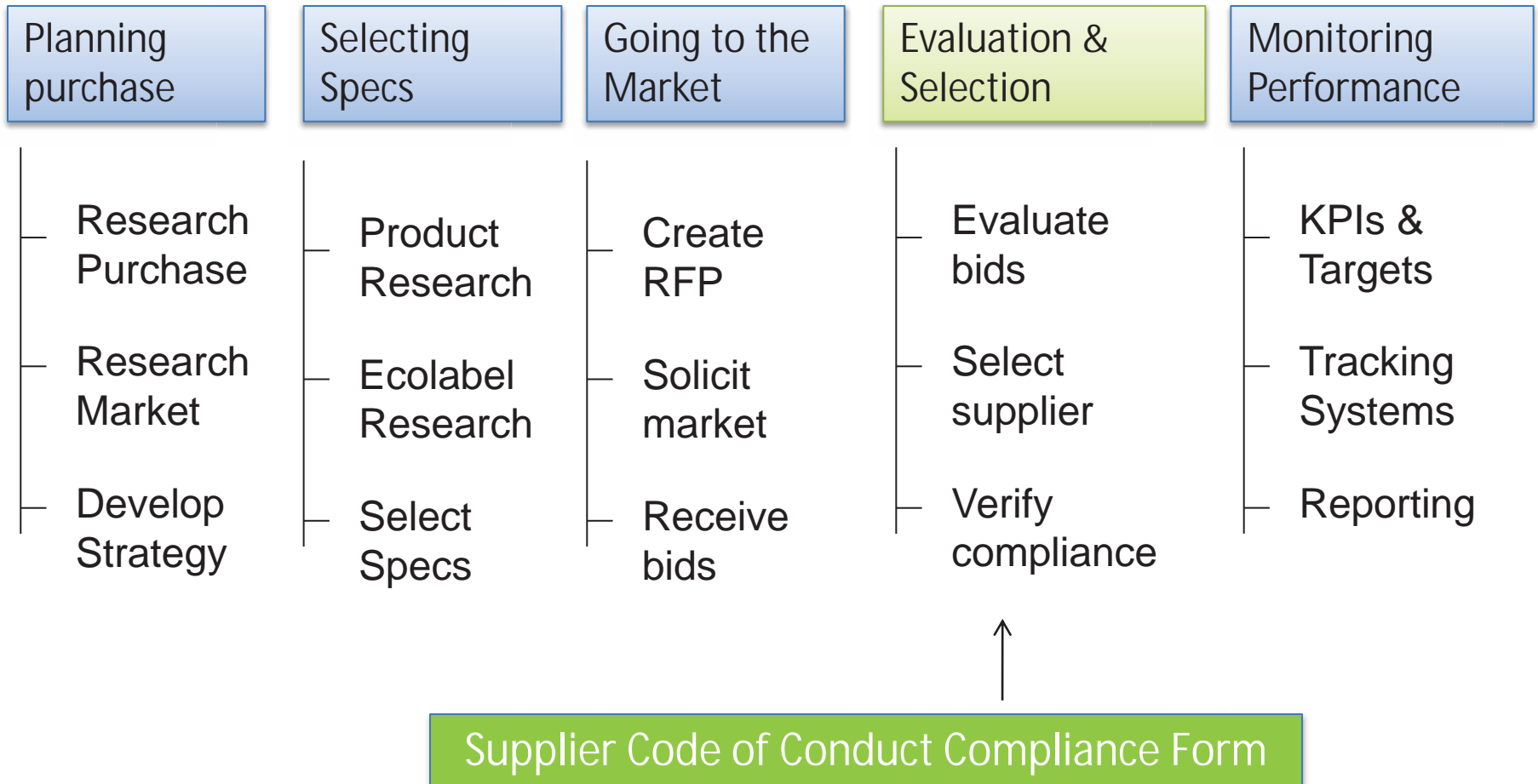

# Injecting Sustainability into Centralized Procurement Processes

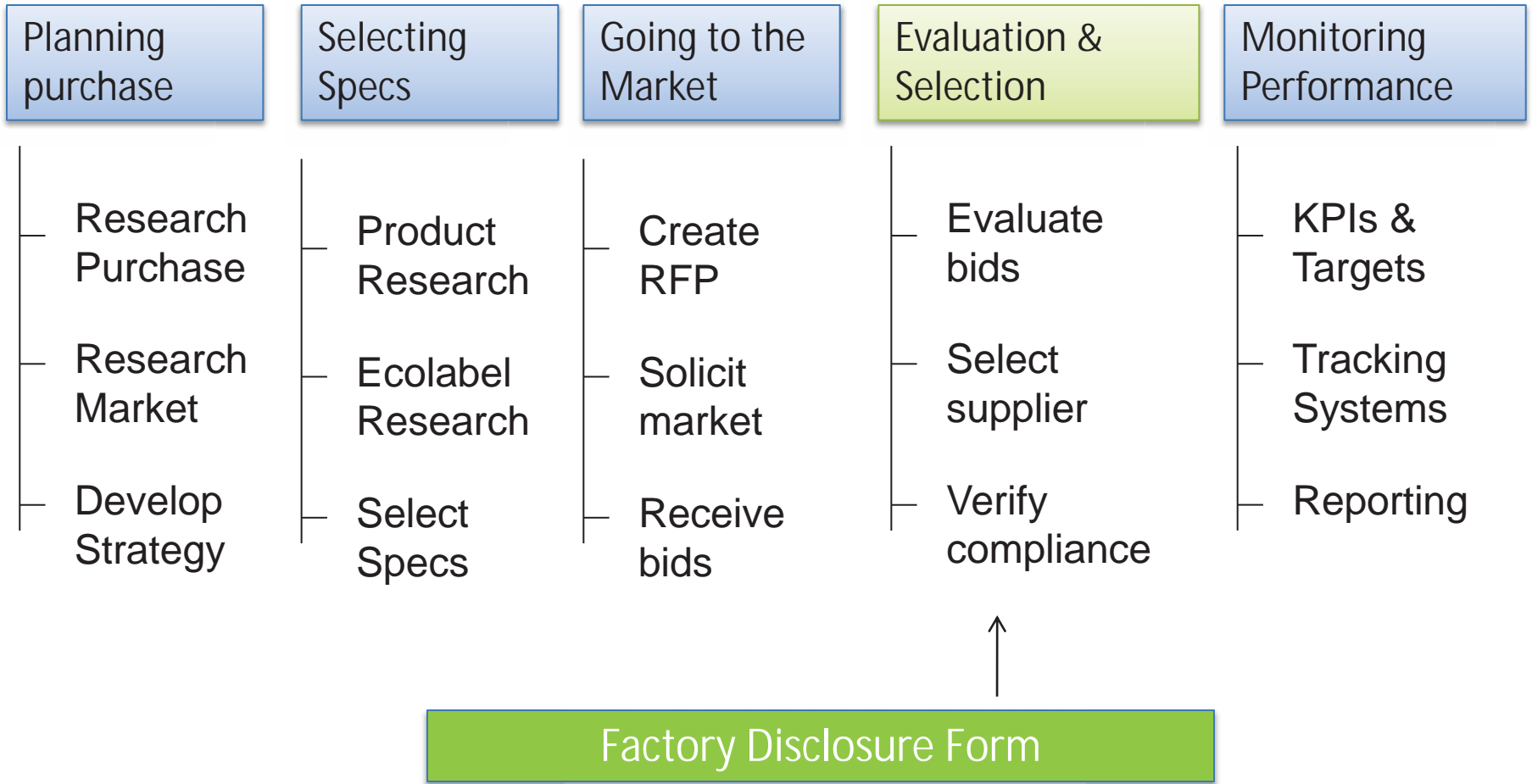

# Injecting Sustainability into Centralized Procurement Processes

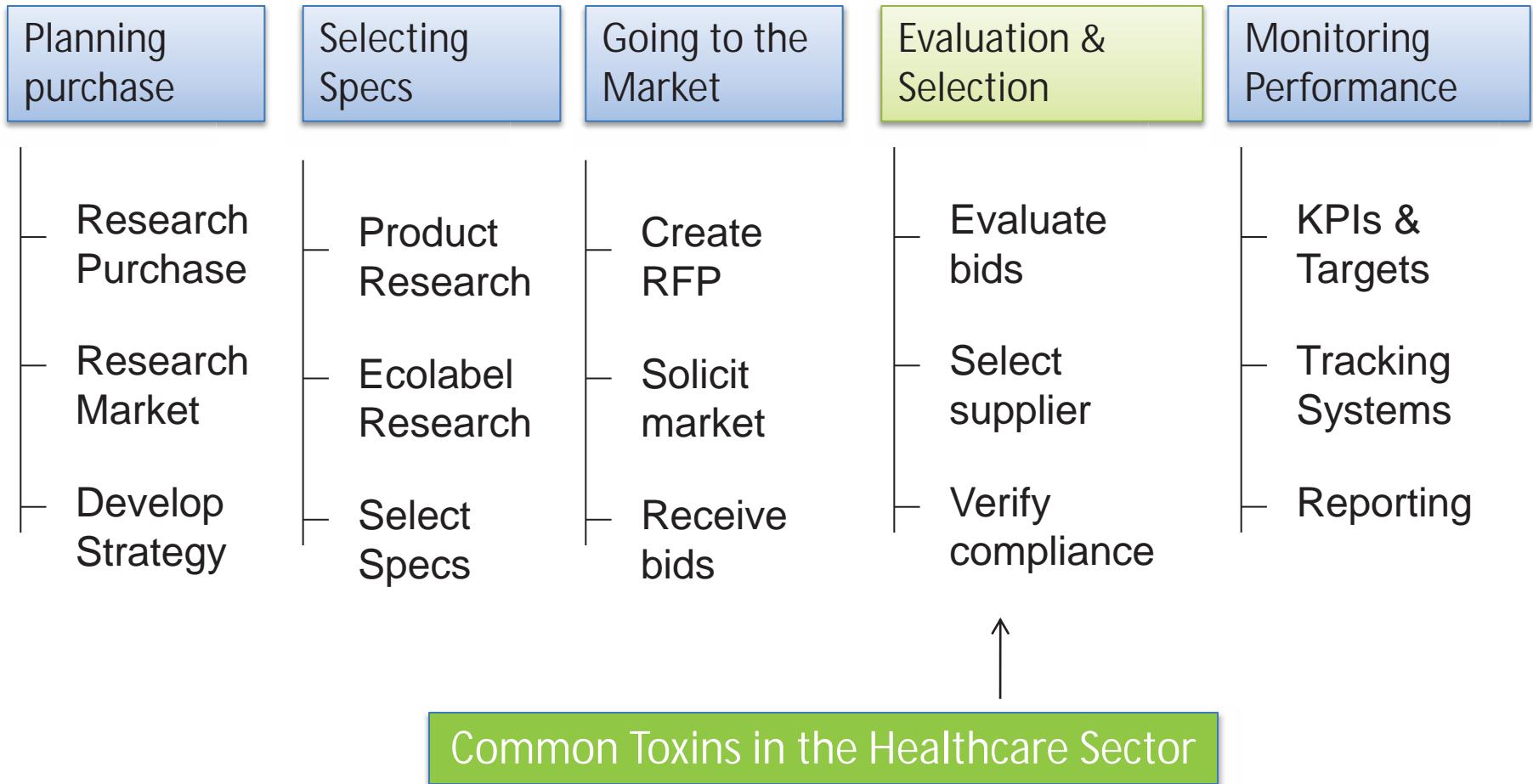

# Injecting Sustainability into Centralized Procurement Processes

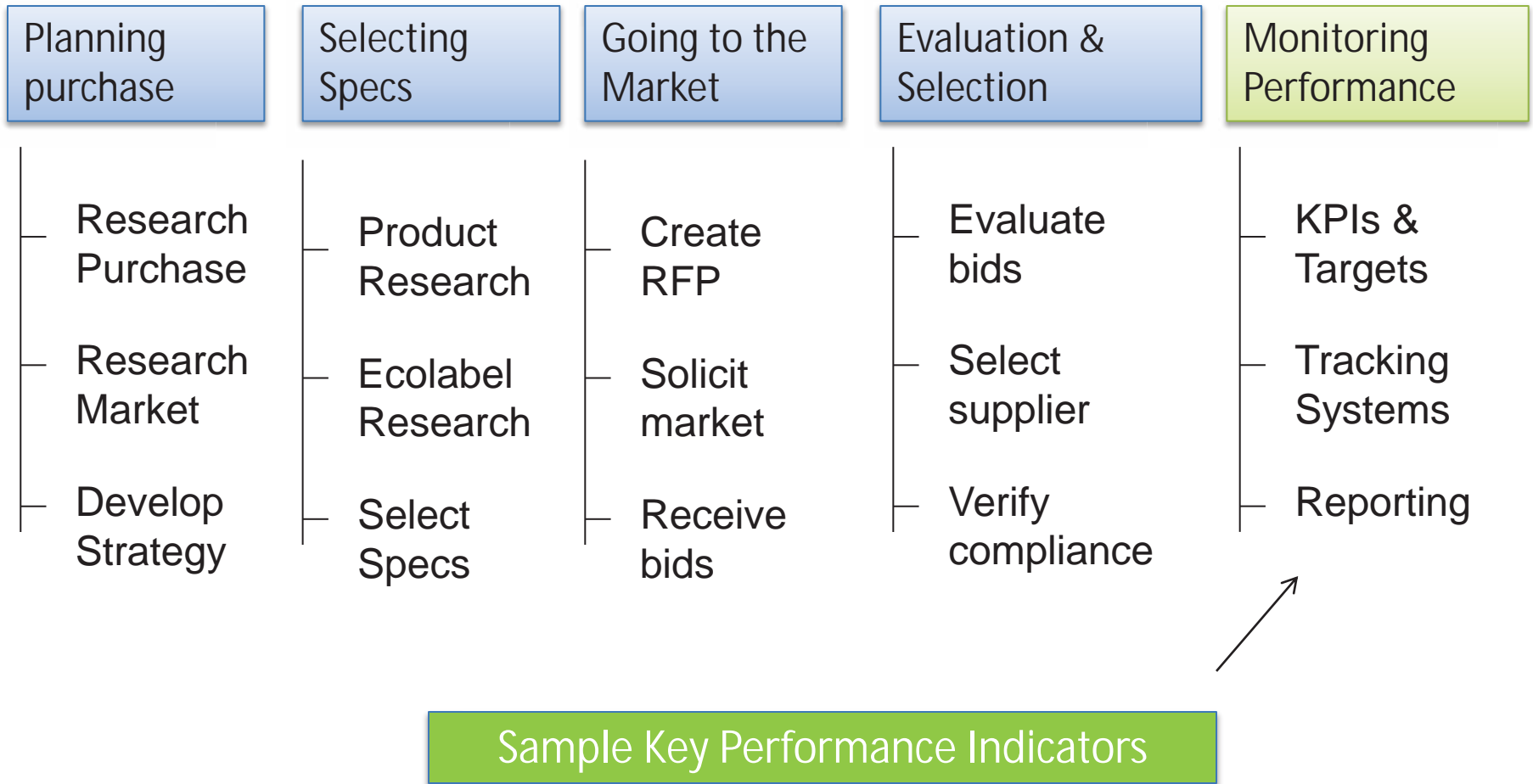

# Integrating sustainability into evaluation matrices

Selection Criteria	Weighting (%)	Supplier A	Supplier B
Price	30		
Quality	30		
Service	30		
Sustainable product./service design*	5		
Sustainability leadership**	5		
<b>Total</b>	<b>100%</b>		

\* Calculated using desirable sustainability clauses score guide

\*\* Calculated using sustainability leadership questionnaire

# Integrating sustainability into evaluation matrices

Selection Criteria	Weighting (%)	Supplier A	Supplier B
Price	30	30	
Quality	30	30	
Service	30	30	
Sustainable product./service design*	5	3	
Sustainability leadership**	5	2	
<b>Total</b>	<b>100%</b>	<b>95</b>	

\* Calculated using desirable sustainability clauses score guide

\*\* Calculated using sustainability leadership questionnaire

# Integrating sustainability into evaluation matrices

Selection Criteria	Weighting (%)	Supplier A	Supplier B
Price	30	30	30
Quality	30	30	30
Service	30	30	30
Sustainable product./service design*	5	3	5
Sustainability leadership**	5	2	4
<b>Total</b>	<b>100%</b>	<b>95</b>	<b>99</b>

\* Calculated using desirable sustainability clauses score guide

\*\* Calculated using sustainability leadership questionnaire

# Diving Deep on Sustainable Purchasing

- **Shannon Clohosey**  
Sustainability Projects Manager, City of Whitehorse

*----insert Shannon's slides*

# Diving Deep on Sustainable Purchasing

- **David Knight**

Manager, Procurement Services, Highways and Public Works, Yukon Government

*----place holder for David's slides*

# Diving Deep on Sustainable Purchasing

- **Melissa Hall**

Corporate Services, Aboriginal Affairs & Northern  
Development Canada (AANDC)

*----place holder for slides*

# Diving Deep on Sustainable Purchasing

- **Lacia Kinnear**

Manager of the Northern Climate Exchange, Yukon College

----place holder for slides

# Workshop Agenda

1. Registration and Refreshments (8:00-8:30 AM)
2. Kick-off and Welcome (8:30-9:00 AM)
3. Drivers for Public Sector Sustainable Purchasing (9:00 -10:15 AM)
4. Coffee Break (10:15–10:30 AM)
5. Sustainable Purchasing Trends & Best Practices (10:30 -11:45 AM)
6. Lunch Break (11:45 AM – 12:30 PM) & Keynote Lunch Speaker (12:30-1:15 PM)
7. Afternoon Plenary Session – Diving Deep on Sustainable Purchasing (1:15-2:45 PM)
8. **Coffee Break (2:45 – 3:00 PM)**
9. Concurrent Breakout Sessions – Choose One (3:00-4:00 PM)
10. Wrap-up, Next Steps & Evaluation (4:00-4:30 PM)



# Workshop Agenda

1. Registration and Refreshments (8:00-8:30 AM)
2. Kick-off and Welcome (8:30-9:00 AM)
3. Drivers for Public Sector Sustainable Purchasing (9:00 -10:15 AM)
4. Coffee Break (10:15–10:30 AM)
5. Sustainable Purchasing Trends & Best Practices (10:30 -11:45 AM)
6. Lunch Break (11:45 AM – 12:30 PM) & Keynote Lunch Speaker (12:30-1:15 PM)
7. Afternoon Plenary Session – Diving Deep on Sustainable Purchasing (1:15-2:45 PM)
8. Coffee Break (2:45 – 3:00 PM)
9. **Concurrent Breakout Sessions – Choose One (3:00-4:00 PM)**
10. Wrap-up, Next Steps & Evaluation (4:00-4:30 PM)

# Concurrent Breakout Sessions

## Stream A: Technical Training & Skills Development

- **Tim Reeve**  
President, Reeve Consulting- Applying Scorecards and Measuring Sustainability
- **David Knight**  
Manager, Procurement Services, Highways and Public Works, Yukon Government

## Stream B: Collaboration Opportunities for Governments, Groups and Agencies

- **Rebecca World**  
Climate Change Outreach Coordinator, Yukon Government Climate Change Secretariat
- **Melissa Hall**  
Corporate Services, Aboriginal Affairs & Northern Development Canada

# Concurrent Breakout Sessions

## Stream A: Technical Training & Skills Development

- **Tim Reeve**  
President, Reeve Consulting- Applying Scorecards and Measuring Sustainability
- **David Knight**  
Manager, Procurement Services, Highways and Public Works, Yukon Government

*----place holder for slides*

# Concurrent Breakout Sessions

## Stream B: Collaboration Opportunities for Governments, Groups and Agencies

- **Rebecca World**

Climate Change Outreach Coordinator, Yukon Government  
Climate Change Secretariat

- **Melissa Hall**

Corporate Services, Aboriginal Affairs & Northern Development  
Canada

-----place holder for slides

# TOTAL COST OF OWNERSHIP

## **What is Total Cost of Ownership?**

A Sustainable Purchasing Strategy serves as the management framework within which Total Cost of Ownership analysis is applied. Total Cost of Ownership is a decision support method or approach linked to “Total Cost Assessment”, “Full Cost Accounting” and “Life Cycle Analysis” – other ways of evaluating environmental and financial costs.

# TOTAL COST OF OWNERSHIP

## Total Cost of Ownership & How It Can Advance Sustainability Purchasing

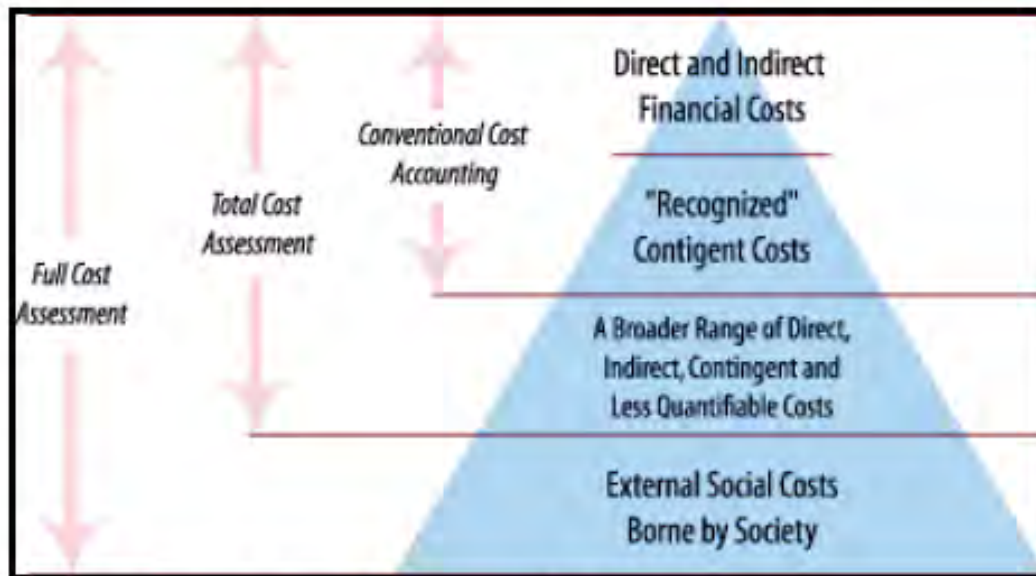

**Figure - 1 Types of Cost Assessment Tools**

Diagram credit to Business & Sustainable Development

# TOTAL COST OF OWNERSHIP

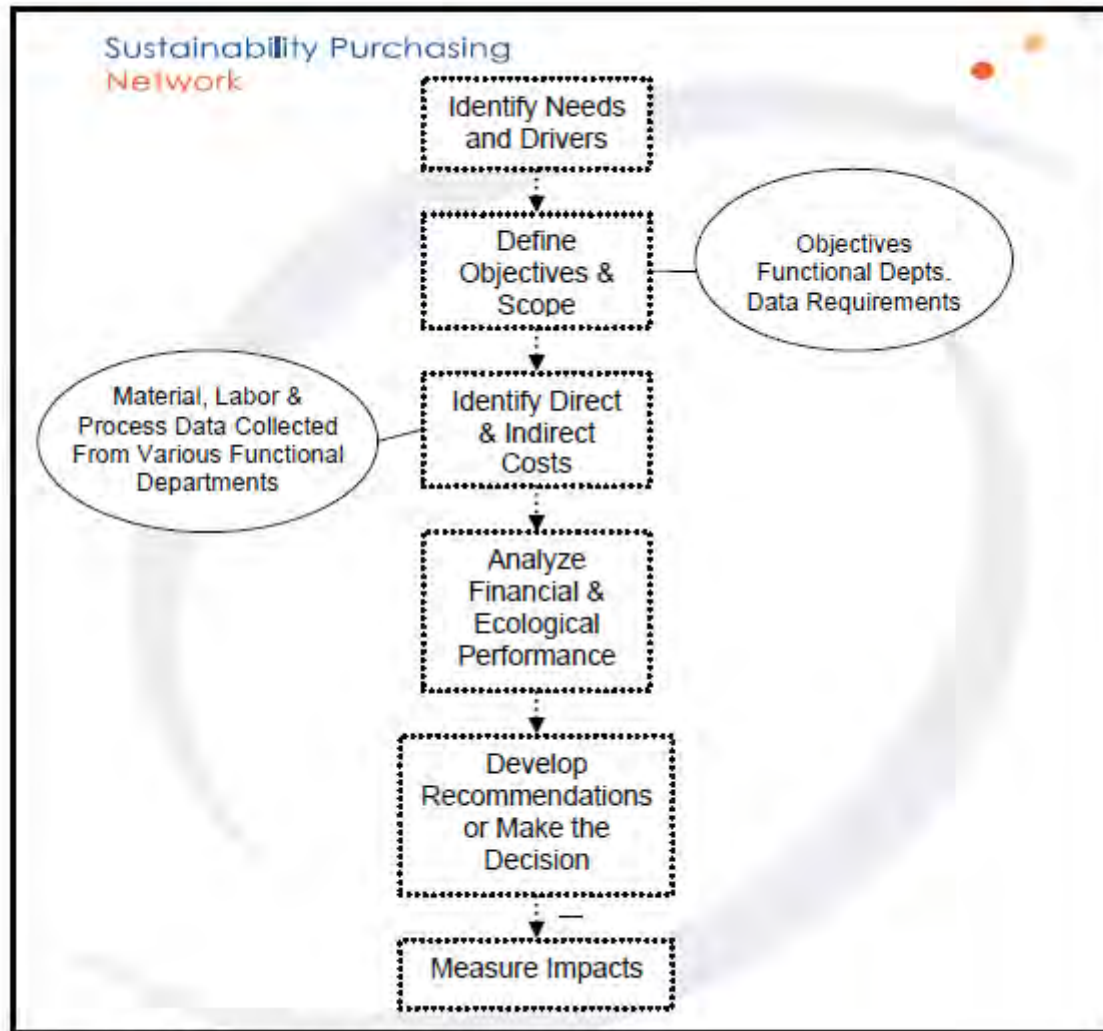

Figure 2 - 6 Steps of Total Cost of Ownership

# TOTAL COST OF OWNERSHIP

## Environmental Objectives

Biodegradability of products and substances

Energy efficiency of products or operating systems

No genetically modified organisms (GMOs)

Organic and natural characteristics

Recycled material composition / eco-efficient materials

Packaging and/or product take-back programs

Recyclability of products, packaging or components (including electronics)

Reduced emissions to air, land and water

Reduction or elimination of toxic and hazardous material substances

# TOTAL COST OF OWNERSHIP

## Social & Ethical Objectives

Local job creation and locally produced products & services

Local community development

Fair Trade and human rights

Product health and safety implications (worker health and safety)

Animal welfare

Corporate responsibility

Governance and accountability framework for vendors / suppliers

Internationally accepted (ILO) standards for factory conditions

Supplier human resources policies

# PLUG & PLAY SUSTAINABILITY CLAUSES

## Packaging Reduction Clause

We aim to reduce the packaging associated with acquiring various products and services. More and more suppliers are introducing innovative programs to reduce packaging. Examples include providing products in reusable packaging such as plastic totes, reducing unnecessary packaging such as shrink wrap or offering packaging that is made from recycled material. Please tell us about any initiatives your company has undertaken to reduce product packaging.

<i>Score</i>	<i>Description</i>
0	No response or information provided not applicable (e.g. not related to product or service in question)
1	The majority of the supplier's packaging is recyclable and can be recycled in the City's recycling system
2	One or more of the following is in place: <ul style="list-style-type: none"> <li>• Product packaging is made of high-content post-consumer recycled materials (75% or more) and is fully recyclable</li> <li>• Product packaging holds a third-party Type I eco-label (see definitions below), ensuring it meets a set of environmental standards</li> <li>• Supplier has a strategy in place to minimize or 'light-weight' packaging</li> </ul>
3	Supplier has a product stewardship program in place that addresses one or more of the above attributes and one of the following: <ul style="list-style-type: none"> <li>• Supplier packaging is made of high-content post-consumer recycled materials, is fully recyclable and supplier takes back all for recycling</li> <li>• Supplier uses reusable containers, made of recycled or eco-friendly materials, and takes back all for reuse</li> </ul>

# PLUG & PLAY SUSTAINABILITY CLAUSES

<b>Greenhouse Gas/Carbon Reduction Clause</b>	
We aim to reduce its greenhouse gas/carbon emissions where possible. Tell us how the design and use of your product or service takes into account strategies to reduce greenhouse gas/carbon emissions. Examples could include offering products with a limited amount of embedded carbon, having a strategy for limiting transportation related to service provision and/or purchasing carbon credits to offset emissions.	
<i>Score</i>	<i>Description</i>
0	No response or information provided not applicable (e.g. not related to product or service in question)
1	If one of the following is in place: <ul style="list-style-type: none"> <li>• Product/service delivery uses low emission vehicles</li> <li>• Product production uses alternative energy, such as wind or solar power</li> <li>• Service provider's supplies are produced using wind or solar power</li> <li>• Low emission equipment/machinery used in service provision</li> <li>• Product is designed for energy efficiency</li> </ul>
2	Two or more of the following are in place: <ul style="list-style-type: none"> <li>• Product/service delivery uses low emission vehicles</li> <li>• Product production uses alternative energy, such as wind or solar power</li> <li>• Service provider's supplies are produced using wind or solar power</li> <li>• Low emission equipment/machinery used in service provision</li> <li>• Product is designed for energy efficiency</li> </ul>
3	If two or more of the above attributes are in place and the product/service is verified as carbon neutral by an independent third-party

# Workshop Agenda

1. Registration and Refreshments (8:00-8:30 AM)
2. Kick-off and Welcome (8:30-9:00 AM)
3. Drivers for Public Sector Sustainable Purchasing (9:00 -10:15 AM)
4. Coffee Break (10:15–10:30 AM)
5. Sustainable Purchasing Trends & Best Practices (10:30 -11:45 AM)
6. Lunch Break (11:45 AM – 12:30 PM) & Keynote Lunch Speaker (12:30-1:15 PM)
7. Afternoon Plenary Session – Diving Deep on Sustainable Purchasing (1:15-2:45 PM)
8. Coffee Break (2:45 – 3:00 PM)
9. Concurrent Breakout Sessions – Choose One (3:00-4:00 PM)
10. **Wrap-up, Next Steps & Evaluation (4:00-4:30 PM)**

# Questions?



# Workshop Evaluation

We want your feedback on this session



Excellent  
 Very good  
 Good  
 Average  
 poor

# Contact YICES for further information...

----insert contact details